

Authors' Response

Editor Decision

Comments to the Author:

Dear Mingdong Wei,

based on positive feedback from the two referees, I am pleased to formally accept your paper for its publication with minor revisions in The Cryosphere.

Owing to constructive remark of the Referee #2 (about the way the effect of temperature is discussed in the manuscript), I am choosing "publish subject to minor revisions" and encourage you to consider this remark very carefully as you prepare your final text, which I will go through one more time.

Thank you for your patience with this slow process, but all of us are dealing with multiple issues these days.

Best regards,

Evgeny Podolskiy

Re: We sincerely thank Prof. Podolskiy very much for the valuable time devoted to improving our manuscript. We have further modified the manuscript according to the comments from Referee #2.

Referee #1

The manuscript was well revised according to the reviewers' comments. The new version of the manuscript clearly provides new methods along with the obtained results and does not confuse the reader whether temperature or other "immersed" conditions play a more important role in the ice behavior under cycling. The new Conclusion is divided into two parts and differentiate well between the novel test setup and main results that were obtained.

The results on cyclic loading of floating ice specimens obtained through the novel well-designed experimental methods & setup must be important for the further development of research on the mechanical properties of ice. The underlying physical processes are described and give a good agreement with numerical simulations.

Therefore, I recommend publication of this manuscript in "The Cryosphere".

Re: We thank the reviewer for the insightful comments and valuable time.

Referee #2

Summary

The authors have responded to the majority of my comments from my first review and I believe the manuscript has been improved as a result. In particular, I am happy to see more details provided on the method used to estimate values for E_0 and r and to see a clearer explanation of the temperature dependence of these variables and their relationship to the observed higher rates of strain for warmer "floating" ice. However, I am still surprised to find no discussion of the temperature dependence of viscous strain. I am also puzzled by the authors' response to one of reviewer 1's comments that the "original intention of this study is not to investigate the effect of temperature and floating condition on ice behavior". I feel this understates the authors' work and the resulting changes to the text detract from the overall quality of the manuscript.

Re: We thank Prof. Mahoney for the constructive comments and valuable time. Detailed responses to these issues can be found behind the major comments.

Major comments:

1. Still no discussion of temperature dependence of viscous strain component

According to equation 10, the differences in ice temperature between the wet and dry experiments ought to result in an approximately two-fold difference in the viscous component of strain, ϵ_v . This should be discussed on more detail in relation to the overall increase in strain observed in the “floating” ice.

Re: The last paragraph of this paper discusses this. Please note that, although the differences in ice temperature between the floating and dry experiments appear to result in an approximately two-fold difference in the viscous component of strain, ϵ_v , this does not mean that the temperature will make the viscous strain component of the floating ice only twice that of the dry ice. For example, the overall increase in strain for specimen Floating-5ppt-1 is much higher (fifteen times more) than that for specimen Dry-5ppt-1. This is mainly due to the aforementioned increase in effective dislocation density with increasing temperature (Cole and Durell, 2001; Cole, 2020). Corresponding discussion has been added in the revised manuscript (lines 402-408).

2. Ambiguous premise of paper

In their response to reviewer 1’s comment 13, concerning the processes being tested by the experiment design, the authors state that “the original intention of this study is not to investigate the effect of temperature and floating condition on ice behavior” and the manuscript should instead be considered as a methods paper, as reflected by a minor restructuring of the conclusions section. I find this to be a disappointing climb-down, when I would have preferred to see a clarification of the conclusions that can be drawn from the authors’ novel laboratory method.

Re: Earlier laboratory work on ice has mostly focused on dry, cold and isothermal ice. Here we wish to draw attention to the fact, that the results from such experiments may not apply directly to saline ice in its natural conditions, that is, when ice is floating in water – and also to the fact that the experiments where these conditions are mimicked in the laboratory can be performed. At this stage of the work we do not aim to study all of the factors that influence ice behavior. This point is now quite clear in the manuscript as explained in detail in our response to reviewer 1’s comment.

Thus, in our response to reviewer 1’s comment 13, we mean that the original intention of this study is not to study the effect of temperature on ice behavior (which usually requires a series of experiments with various ice temperatures) and not to explore the temperature-independent effect of water on ice behavior (which requires the ice to be tested under dry and wet conditions at a given ice temperature).

Our study does not fall into these two categories.

I also find this to be an entirely unconvincing argument. If the study was intended to be an investigation into the effects of temperature and floating conditions, why did the authors include experiments on both cold, isothermal non-floating ice and poly-thermal floating ice? Instead of removing references “wet” experiments, I urge the authors to revert to their nomenclature and instead spend a little extra text speculating on how floating, polythermal ice might respond differently to nonfloating ice with an equivalent average temperature.

Re: The manuscript has been modified in response to this comment (see lines 62-64). Although we regret the reviewer’s disappointment, the fact is that the dry experiments with cold, isothermal non-floating ice were conducted to validate the performance of our newly developed testing apparatus and experimental methods, and the constitutive model under commonly used test conditions. Moreover, the dry, isothermal results provide a point of comparison for the floating ice results. The current nomenclature has satisfied reviewer 1 and is considered suitable by many experienced experts, which we have consulted.

In the manuscript, we have not speculated how floating, polythermal ice might respond differently to nonfloating ice with an equivalent average temperature.

In its current form, the premise of the manuscript is ambiguous and despite removing references to “wet” experiments, the text still contains phrases like “Thus, the fact that the ice was in contact with water and had a realistic temperature profile ...” (line 365), which still contribute to the misunderstanding that the authors are studying the effect of water on ice behavior.

Re: We have further modified the manuscript accordingly (lines 368 and 389), including the sentence that is considered misleading by the reviewer. Now it is obvious enough in the full text that this is not a type of study comparing the mechanical behavior of wet ice and dry ice at the same ice temperature (i.e., simply studying temperature-independent water effect).

Strain response and energy dissipation of floating saline ice under cyclic compressive stress

Mingdong Wei¹, Arttu Polojärvi¹, David M. Cole², Malith Prasanna¹

¹Aalto University, School of Engineering, Department of Mechanical Engineering, P.O. Box 14100, FI-00076 Aalto, Finland.

²ERDC-CRREL (Ret.), 72 Lyme Rd., Hanover, NH 03768, USA

Correspondence to: Arttu Polojärvi (arttu.polojarvi@aalto.fi)

Abstract. Understanding the mechanical behavior of sea ice is the basis of ice mechanics applications. Laboratory-scale work on saline ice has often involved dry, isothermal ice specimens due to the relative ease of testing. This approach does not address the fact that the natural sea ice is practically always floating in seawater and typically has a significant temperature gradient. To address this important issue, we have developed equipment and methods for conducting compressive loading experiments on floating laboratory-prepared saline ice specimens. The present effort describes these developments and presents the results of stress-controlled sinusoidal cyclic compression experiments. We conducted the experiments on dry, isothermal (-10°C) ice specimens and on floating ice specimens with a naturally occurring temperature gradient. The experiments involved ice salinities of 5 and 7 ppt, cyclic stress levels ranging from 0.04–0.12 MPa to 0.08–0.25 MPa and cyclic loading frequencies of 0.001 Hz to 1 Hz. The constitutive response and energy dissipation under cyclic loading were successfully analyzed using an existing physically based constitutive model for sea ice. The results highlight the importance of testing warm and floating ice specimens and demonstrate that the experimental method proposed in this study provides a convenient and practical approach to perform laboratory experiments on floating ice.

1 Introduction

Climate change has led to an increased interest in polar sea areas and on ice behavior, since accurate predictions on the evolution of the ice conditions are crucial for modeling the future climate. Warming climate has also resulted in a search for more efficient marine transit routes, production of offshore wind power, industrial operations related to extraction of hydrocarbons, and even tourism in the north (Gagne et al., 2015; Serreze and Stroeve, 2015; Kern et al., 2019). Structural loads due to sea ice make these activities challenging. In-depth understanding of the physical and mechanical properties of sea ice is required to develop tools for modeling future ice conditions, the related ice–ice and ice–wave interaction problems, and for the design of safe and sustainable offshore structures

29 (Dempsey, 2000; Feltham, 2008, Herman et al., 2019a,b; Lu et al., 2018a,b; Ranta et al., 2017, 2018a,b; Tuhkuri
30 and Polojärvi, 2018; Polojärvi et al., 2015; Voermans et al., 2019; Cheng et al., 2019; Li et al., 2015).

31 This paper studies the mechanical behavior of laboratory-prepared saline ice specimens under cyclic loading. This
32 type of loading occurs in wave–ice and some ice–ice and ice–structure interaction problems – all important in the
33 changing polar environment. For example, warming climate causes an increase in the amount of open water and
34 broken ice fields, which strengthens the impact of waves on sea ice. From the perspective of pure ice mechanics
35 and modeling of ice, the cyclic loading experiments yield information on the elastic and viscoelastic components
36 of strain and their dependence on the physical, or microstructural, characteristics of the ice. The cyclic loading
37 tests also give insight into the fatigue of ice (Haskell et al., 1996; Bond and Langhorne, 1997; Langhorne et al., 1998;
38 Mellor and Cole, 1981; Murdza et al., 2019; Schulson and Paul, 2009; Iliescu et al., 2017; Iliescu and Schulson,
39 2002).

40 Cyclic loading experiments on freshwater ice have been performed since the forties (Kartashkin, 1947; Mellor and
41 Cole, 1981) and on saline ice since the eighties (Tabata and Nohguchi, 1980; Cole, 1995; Cole and Durell, 1995;
42 Cole et al., 1998). Cole and Durell (1995) studied the effects of temperature (from -5 to -50°C), cyclic stress
43 amplitude (from 0.1 to 0.8 MPa) and loading frequency (from 10^{-3} to 1 Hz) on the response of laboratory-grown
44 saline ice; the ice response was revealed sensitive to variations in these factors. Cole et al. (1998) investigated the
45 response of columnar first-year sea ice to cyclic loading and found that the elastic, anelastic, and viscous strains
46 varied according to the relation between the loading and preferred c-axis directions of the specimens. More recently,
47 Heijkoop et al. (2018) conducted strain-controlled cyclic compression tests on sea ice to ascertain the variation of
48 storage and loss compliances versus frequency. All of this earlier work has been performed using isothermal, dry
49 specimens.

50 An often-overlooked issue in laboratory-scale experimentation is that most sea ice problems involve ice that is
51 floating on water. Floating ice commonly has a through-thickness temperature gradient, resulting in a through-
52 thickness gradient in its mechanical properties. The latter point is important to address in experimentation and
53 modeling. The temperature gradient is implicitly taken into account in in-situ experiments on floating ice
54 (Langhorne et al., 2015; Smith et al., 2015; Wongpan et al., 2018). The cost of in-situ experimental campaigns,
55 however, is high and the experiments often require specially designed loading devices (Vincent and Dempsey,
56 1999; Dempsey et al., 1999, 2018; Cole and Dempsey, 2004). Consequently, the relatively low costs and
57 convenience of laboratory-scale work motivate the development of viable methods for laboratory-scale
58 experiments on floating ice. Such experiments can be used, for example, for thorough validation of material models
59 aiming to account for the temperature gradient in ice.

60 In the study presented here, stress-controlled sinusoidal cyclic compression experiments were performed on
61 laboratory-grown, non-oriented columnar saline ice specimens floating on salt water and repeated on dry,
62 isothermal (-10°C) specimens. **The dry experiments were conducted to validate the performance of our newly
63 developed testing apparatus and experimental methods under commonly used test conditions. Moreover, the results
64 provide a reference on the different mechanical behavior of floating ice from that of the ice under such conditions.**
65 The varied parameters were the ice salinity, cyclic stress amplitude and mean stress level, and the frequency of
66 cyclic loading. The results are comprehensively analyzed and discussed, and are shown to compare favorably with
67 the predictions of an existing physically-based constitutive model (Cole,1995). Techniques and observations
68 yielding increased insight of the behavior of sea ice in its natural conditions are introduced; Insight on floating,
69 rather warm, ice is important, as future sea ice is expected to be on average warmer than now (Boe et al., 2009;
70 Blockley and Peterson, 2018; Ridley and Blockley, 2018).
71 The paper is organized as follows. Section 2 describes the specimen preparation, the experimental set-up, and the
72 matrix of experimental variables. Section 3 presents the results from the experiments. Section 4 addresses
73 constitutive modeling and Section 5 discusses our findings with references to earlier work and Section 6 gives our
74 conclusions.

75 **2 Laboratory experiments of saline ice under cyclic loading**

76 **2.1 Saline ice specimen preparation and characterization**

77 The ice was grown in the cold room of Department of Mechanical Engineering, Aalto University using a tank
78 having dimensions of 1.15 m × 1.15 m × 0.98 m (width × length × depth) and meltwater salinities of 24 and 34
79 ppt. Rigid foam insulation was placed on the sides and bottom of the tank and heating cables were placed around
80 the bottom perimeter to inhibit freezing from the structural members of the tank. Additionally, a hose for draining
81 excess water was installed near the base of the tank, to prevent the accumulation of water pressure under the ice
82 sheet during its growth. Such pressure could cause microcracking of ice or generate additional loads on the tank.
83 Specimens having the nominal dimensions of 0.60 m × 0.30 m × 0.10 m were prepared by placing high-density
84 polyethylene molds into the tank before seeding (Figure 1). The tolerance of the specimen dimensions was ±2 mm
85 (in all stress calculations below, the measured dimensions of the specimens were used). The molds floated with
86 2–3 mm of freeboard. Next, the saline water was chilled to about -1.5°C, the cold room temperature dropped to ≈
87 -20°C and the tank was seeded by spraying very fine mist of fresh water over the tank as is typically done to seed
88 ice sheets in larger-scale test basins (Gow, 1984; Li and Riska, 1996).

89 After the seeding, the room temperature was increased to -14°C for three days and then -10°C for two days to
90 produce the desired specimen thickness of 10 cm. The ice sheets made using 24 ppt and 34 ppt-saline water reached
91 average salinities of 5 and 7 ppt, respectively, and their densities were 886 ± 19 and $879\pm 16\text{ kg}\cdot\text{m}^{-3}$, respectively.
92 The specimens used in the dry experiments (Figure 2a and 3) were sealed in plastic bags and stored in a freezer at
93 -10°C for 1–2 days before testing. However, for the floating ice experiments (see Figure 2b), the specimens were
94 ejected from the molds, placed in plastic bags with water from the growth tank and quickly transferred to the test
95 basin to minimize brine drainage during the transfer.
96 Before the experiments, the columnar microstructure of the ice was verified by producing and inspecting thin
97 sections as detailed by Langway (1958). Of special interest was the microstructure close to the specimen
98 boundaries since such molds are somewhat uncommon in ice specimen preparation. Figure 4 shows two typical
99 thin sections from near the boundary of a specimen produced using 24-ppt-saline water; one is for the vertical and
100 the other for the horizontal direction as indicated. Figure 4a shows the columnar structure of the ice. The horizontal
101 view in Figure 4b provides a way to estimate the average grain size by dividing the section area by the number of
102 grains; the average grain size was $\approx 3.5\text{ mm}$. The Schmidt equal area net pole projection for one of the thin sections
103 shown in Figure 5 confirms that the c-axes were unaligned in the horizontal plane, as intended.

104

105 **2.2 Equipment, test matrix and experimental procedure**

106 The experiments were conducted in the same cold chamber used for the saline ice production. As Figures 2 and 3
107 illustrate, an externally mounted electrohydraulic cylinder applied loads to the specimens. The piston passed
108 through a sealed port in the side of the test tank. The piston had a maximum stroke of 800 mm and a loading
109 capacity of 100 kN for compression and 60 kN for tension. The load cell had an accuracy of $\pm 5\text{ N}$, which is
110 sufficient for all stress levels and cycles of the experiments here. The test basin was constructed of waterproof
111 plywood. The system employed a camera for remote monitoring of the experiments, a three-channel temperature
112 datalogger to record the temperature profile of floating ice during testing, a Data Acquisition Processor (DAP)
113 board (model: Data Translation DT9834), and fixtures for arranging displacement sensors to the ice specimens.
114 The temperature datalogger had a maximum sampling rate of one datum per five seconds, its measurement range
115 was from -100 to 1300°C , and an accuracy of $\pm 0.5^{\circ}\text{C}$. The DAP board could achieve a maximum scan rate of
116 500,000 samples per second.

117 The loading system has a self-equilibrating geometry in that the compressive force applied by the electrohydraulic
118 piston and transmitted through the specimen is balanced by a tensile force in the external load frame (Figure 3).
119 Care was taken to center the loading piston and the reaction plates on the vertical dimension of the load frame.

120 The ice deformation was measured as follows. Before the test, two holes were drilled on the specimen. Two iron
121 rods with the cross-section of 5 mm × 5 mm were then inserted into the holes and frozen in place using a small
122 quantity of cold fresh water. The relative displacement of the rods was monitored by two linear variable differential
123 transformer transducers (LVDTs, model: HBM WA2, with a measurement range and accuracy of 2 and ± 0.001
124 mm, respectively). This relative displacement was used to determine the strain response of the specimen. As shown
125 in Figures 2 and 3, the LVDTs were mounted on a rectangular steel placed across the basin.

126 The air temperature was kept at -10°C during all testing. To measure the through-thickness temperature gradient
127 in all of the floating ice experiments, temperature probes were frozen into three 2.5 mm-diameter, 50 mm deep
128 holes were drilled on one side face of the specimen. As shown in a sketch of Figure 6a, one measurement point
129 was in the middle of the specimen from the vertical direction, and the other two were 1.5 mm away from the upper
130 and lower surfaces of the specimen, respectively. During each floating ice experiment, temperature readings from
131 all three channels remained constant for the duration of the experiment, indicating that the thermal gradient was
132 unaffected by the cyclic loading.

133 Figure 6b presents typical temperature profiles measured in two floating ice specimens. For the 5-ppt-saline
134 floating ice, the temperature near the top surface, in the middle and near the bottom surface of the specimen was
135 measured to be -3.0, -2.3 and -2.2°C, respectively, while the values were -3.1, -2.4 and -2.1°C, respectively, for
136 the 7-ppt-saline ice floe. These temperature readings suggest that the average temperature of the floating ice was
137 -2.5°C, much higher than the air temperature of the cold chamber (-10°C). The water temperature at five
138 centimeters below the water surface was measured to be ≈ -1.8°C in the floating ice tests.

139 The test matrix called for applying relatively low cyclic compressive stress levels with the system in load control.
140 Figure 7 presents the loading waveforms used in the experiments and the test matrix is given in Table 1. In the
141 experiments, the ice was first loaded with a linear ramp to reach an initial compressive stress level, at which point
142 a compressive haversine waveform was immediately applied. In Figure 7a, σ_{\max} and σ_{\min} represent the upper and
143 the lower bounds of the cyclic compressive stress, respectively, and T denotes the period for one loading cycle. As
144 indicated by Table 1, six periods ranging from 1 to 10³ s were employed; these periods cover the main range of
145 ocean wave periods, which usually vary from several seconds to tens of seconds (Reistad et al., 2011; Zijlema et
146 al., 2012). In each dry test, only a fixed frequency was applied. Once the test was completed, the specimen
147 recovered for 15 minutes before subsequent load cycles were applied. For all dry tests, the duration of the initial
148 loading ramp was fixed to be 1 s. In each of the tests corresponding to $T = 1, 5, 10$ and 100 s, 18 cycles were
149 applied ($N = 18$), while for those with $T = 500$ and 1000 s, $N = 9$ and 4, respectively. The sequence of loading
150 cycles was in ascending order of T in all cases. As a time-saving measure, and to avoid freezing of the open water

151 in the basin, cyclic stresses with increasing periods were applied continuously in the floating ice tests. The number
152 of cycles for each period was as follows: $T = 1, 5$ or 10 s, $N = 10$, for $T = 100$ s, $N = 2$, and for $T = 500$ or 1000 s,
153 $N = 1$.

154 The cyclic compressive stress applied to the dry specimens varied from 0.08 to 0.25 MPa, which could be
155 justifiably expected to not lead to severe damage of the specimen while being high enough to generate measurable
156 strain (Cole and Dempsey, 2001). The stress in the floating experiments was lower, varying from 0.04 to 0.12 MPa,
157 to avoid damage. For each case listed in Table 1, two specimens harvested from two ice sheets were subjected to
158 each set of conditions. The specimens were named according to their salinity, test conditions (dry/floating), and
159 the ice sheet from which it originated. For example, specimen name Dry-5ppt-1 indicates that it came from the
160 first 5-ppt-saline ice sheet and was tested under the dry, isothermal conditions.

161 Figure 7b illustrates how the energy dissipation in the cyclic loading experiments was calculated. For common
162 engineering materials subjected to uniaxial cyclic compression, the strain along the compressive direction versus
163 the stress is usually characterized by hysteresis loops. The strain energy density dissipated in a loading cycle can
164 be determined by integrating the stress-strain curve. As shown in Figure 7b, the area under the loading curve
165 (region ABCF) represents the maximum strain energy input via the testing machine during a load cycle, and the
166 area under region CDEF denotes the strain energy released during the unloading portion of the cycle. The energy
167 density dissipation (EDD) in one full loading-unloading cycle is given by the difference between the areas of
168 regions ABCF and CDEF (Liu et al., 2017, 2018). The energy density consumed in the hysteresis loop can, in
169 general, be attributed to the internal friction and, in some cases, damage to the material. For each cycle, the energy
170 dissipation rate (EDR) can be defined as the ratio of the dissipated energy to the input energy, namely the area of
171 the region ABCDE divided by that of the region ABCF.

172 **3 Experimental results**

173 Figure 8 presents strain-time plots obtained from the dry experiments using specimen Dry-5ppt-1 under the
174 indicated conditions. The strain-time curves manifest the following feature: If a line would be drawn through the
175 maximum value for each cycle, the slope of the line would first decrease from its initial value for some number of
176 cycles and then settle down to an almost constant value. This observation means that the strain response of the ice
177 specimen under sinusoidal compressive stress reaches a relatively steady stage after the initial transient of the
178 anelastic strain is exhausted, and that in this steady stage the accumulated viscous or permanent strain increases
179 linearly with time. In addition, Figure 8 shows that the longer the period T of cyclic loading, the larger the strain

180 amplitude in one steady-stage cycle. The total amount of strain does not strictly increase with the loading period.
181 This may be because the loading platen and the specimen did not always achieve perfect contact immediately,
182 causing some error in the strain measured in this initial stage of loading. Once intimate contact was achieved, the
183 measured strain became reliable.

184 Figure 9 shows the stress-strain curves for the same experiments. In each case, the area of the hysteresis loop for
185 the first few cycles was comparatively large, and then gradually decreased to a constant value as the specimen
186 reached the steady deformation stage described in the previous paragraph. For example, the hysteresis loops after
187 the first stress cycle in the dry experiment with $T = 1000$ s are similar; $N = 4$ is enough for the dry specimen at T
188 $= 1000$ s to show steady-state response. Thus, the EDD (Figure 7b) decreases from its initial value to an
189 approximately constant value. It is clear that the steady-state hysteresis loop area increase with the period of the
190 cyclic loading, consistent with earlier studies (Cole, 1990; Murdza et al., 2018; Weber and Nixon, 1996).

191 Figures 10 and 11 display a set of strain-time plots and the corresponding stress-strain curves for the floating ice
192 experiments on the 5-ppt-saline ice specimens, respectively. The curves in these two figures show similar features
193 to those in Figures 8 and 9 for dry experiments: The floating ice also reached a steady state of deformation after
194 some loading cycles and the amplitude of the steady-state strain response still increased with T . Similar to the
195 results of the dry experiments, Figure 11 indicates that the longer the loading period, the larger the strain increment
196 of the floating specimen under one steady-state loading-unloading cycle. Comparison of Figures 9 and 11 in the
197 steady state shows that, for constant T , both the strain increment per cycle and the area of one hysteresis loop, are
198 larger in the floating ice experiments than in the dry experiments even though the stress levels are lower than in
199 the dry experiments. It is thus evident that the decreased stress levels in the floating ice experiments did not fully
200 compensate for the temperature effects on the viscous and viscoelastic components of strain as, for example, the
201 viscous strain rate of floating 5-ppt-saline ice specimen is fourteen times that of the corresponding dry specimen.

202 The energy density dissipation (EDD) and the energy dissipation rate (EDR) per cycle during steady-stage
203 deformation (Section 2.2 and Figure 7b) allow quantitative comparisons of the inelastic behavior of specimens as
204 a function of test conditions. These are presented in Tables 2 and 3 for all, except the 1-second-period, experiments,
205 for which the hysteresis loop areas are too small for accurate measurements. Tables 2 and 3 indicate that both the
206 EDD and the EDR decrease with the increase of loading frequency. Moreover, under the same frequency, the 7-
207 ppt-saline ice has larger EDD and EDR values than the 5-ppt-saline ice irrespective of the experiment type. In
208 addition, the floating ice experiments always exhibit higher EDD and EDR values than the dry experiments
209 regardless of the ice salinities. The differences in the values of EDD are especially significant for low frequencies.

210 For example, in the experiments with $T = 1000$ s, the average value of EDD for the 5-ppt-saline dry specimens is

211 only 24% of that of the 5-ppt-saline floating specimens and 44% of that of the 7-ppt-saline dry specimens. However,
212 for the experiments with $T = 5$ s, the average value of EDD in the former case is 47% and 77% of that in the latter
213 two cases, respectively. Thus, the ice salinity and the test conditions have a more significant influence on the
214 energy dissipation of the ice when the cyclic loading period is long.

215 **4 Material modeling**

216 The hysteresis loops of the stress-strain curves manifest viscous and anelastic properties of the ice. According to
217 previous studies (Cole, 1995; Leclair et al., 1999), in low-stress cyclic loading experiments, the microstructure of
218 the ice remains unaffected by loading, or in other words, no damage occurs within the material. In the present case
219 of polycrystalline ice, the anelastic deformation is mainly attributed to two relaxation mechanisms, lattice
220 dislocation relaxation and grain-boundary sliding. Viscous straining is attributable to basal dislocation glide. In
221 this section, a dislocation-based model (Cole, 1995; Cole and Durell, 2001), which accounts for these mechanisms,
222 is used to predict the strain response of the ice specimens based on their physical properties and experimental
223 conditions. Here the model is only briefly described, but a detailed description can be found from Cole et al. (1998),
224 where the model is also demonstrated to reproduce the viscous and anelastic behavior of dry specimens. Here the
225 applicability of the model in predicting the behavior of floating laboratory-prepared ice specimens subjected to
226 cyclic loading is tested for the first time.

227

228 **4.1 Brief description of the model**

229 In the physically based model by Cole (1995) and Cole and Durell (2001), the axial strain, ε , of ice under uniaxial
230 cyclic compression is considered to be composed of elastic, anelastic (delayed elastic) and viscous components,
231 denoted here as ε_e , ε_a and ε_v , respectively. The axial strain is expressed as

$$232 \quad \varepsilon = \varepsilon_e + \varepsilon_a + \varepsilon_v. \quad (1)$$

233 In the case of sinusoidal stress waveform, ε_e can be written as

$$234 \quad \varepsilon_e = \frac{\sigma(\omega, t)}{E_0}, \quad (2)$$

235 where ω is the angular frequency of the stress waveform and E_0 is the unrelaxed modulus. Although detailed
236 expressions have been developed for the effective elastic modulus as a function of crystallography, brine and gas
237 porosity, and temperature, a simplified approach is adopted in the present effort. The anelastic component ε_a
238 incorporates both above-mentioned relaxation mechanisms to represent the time-dependent recoverable

239 deformation. For the steady-stage deformation, ε_a of ice subjected to sinusoidal compressive stress can be
 240 decomposed as (Cole and Dempsey 2001)

$$241 \quad \varepsilon_a = \sigma(\omega, t) \left[D_1^d(\omega) + D_2^d(\omega) + D_1^{gb}(\omega) + D_2^{gb}(\omega) \right], \quad (3)$$

242 where the compliance terms, D , with the superscripts “d” and “gb” denote the compliances induced by dislocation
 243 and grain boundary sliding, respectively. The compliance terms are defined as (Cole et al., 1998)

$$244 \quad D_1^d(\omega) = \delta D^d \left\{ 1 - \frac{2}{\pi} \tan^{-1} \left[e^{(\alpha^d s^d)} \right] \right\} \quad (4)$$

$$245 \quad D_1^{gb}(\omega) = \delta D^{gb} \left\{ 1 - \frac{2}{\pi} \tan^{-1} \left[e^{(\alpha^{gb} s^{gb})} \right] \right\} \quad (5)$$

$$246 \quad D_2^d(\omega) = \alpha^d \cdot \delta D^d \frac{1}{e^{(\alpha^d s^d)} + e^{(-\alpha^d s^d)}} \quad (6)$$

$$247 \quad D_2^{gb}(\omega) = \alpha^{gb} \cdot \delta D^{gb} \frac{1}{e^{(\alpha^{gb} s^{gb})} + e^{(-\alpha^{gb} s^{gb})}}, \quad (7)$$

248 where $S^d = \ln(\tau^d \omega)$; τ^d is the central relaxation time (Cole and Durell, 1995). α is a so-called peak broadening
 249 term, which accounts for the effect of a distribution in relaxation times of the basal plane dislocations. The grain
 250 boundary relaxation is calculated using similar mathematic expressions as the dislocation relaxation, but has a
 251 different strength, activation energy and peak-broadening term. The activation energy is 1.32 eV for the grain
 252 boundary relaxation and 0.55 eV for the dislocation relaxation (Cole and Dempsey, 2001). The peak-broadening
 253 terms for lattice dislocation relaxation and grain-boundary sliding relaxation are typically ≈ 0.5 and 0.6 ,
 254 respectively, determined experimentally by Cole (1995), Cole and Dempsey (2001) and also validated by Heijkoop
 255 et al. (2018). The strength of the dislocation relaxation is calculated from

$$256 \quad \delta D^d = \frac{\rho \Omega b^2}{K}, \quad (8)$$

257 where b represents Burgers vector ($b = 4.52 \times 10^{-10}$ m); ρ denotes the mobile dislocation density, often found to
 258 be on the order of 10^9 m⁻²; Ω is an orientation factor, determining the average basal plane shear stress induced by
 259 the background normal stress ($\Omega = 1/\pi \approx 0.32$ for a horizontal specimen made of unaligned columnar ice (Cole,
 260 1995)); K is a restoring stress constant, determined as 0.07 kPa for polycrystalline ice in experiments (Cole and
 261 Durell 2001).

262 In Eq. (1), the viscous strain ε_v is often estimated with the following formulae (Cole and Durell, 2001):

$$263 \quad \varepsilon_v = \int_0^t \dot{\varepsilon}_v d\bar{t} \quad (9)$$

$$\dot{\epsilon}_v = \frac{\beta \rho \Omega^{1.5} b^2 \sigma_{\text{creep}}}{B_0} e^{\left(\frac{Q_{\text{glide}}}{kT^*} \right)}, \quad (10)$$

where $\beta = 0.3$, $Q_{\text{glide}} = 0.55$ eV, and $B_0 = 1.205 \times 10^{-9}$ Pa·s. k is Boltzmann's constant, T^* is the temperature in Kelvins. By using the above definitions and equations, the strain of the ice specimen can be finally determined via Eq. (1).

268

4.2 Modeling

In this study, the key quantity to be determined from the experiments is the dislocation density (ρ). With knowledge of the microstructure and orientation factor (Ω), and given the experimental conditions, the anelastic term δD^d and the viscous strain rate can be calculated directly. We opt here to determine E_0 empirically. These were done by trial and error until the stress-strain curves generated by the model matched with those measured in the experiments with $T = 10, 100$ and 500 s. By making the slopes of the modeled and experimental hysteresis loops for $T = 10$ s comparable, E_0 could be determined. This is because the behavior of the specimens is mainly dominated by the un-relaxed modulus E_0 when the loading frequency is high (here 0.1 Hz to 1 Hz), as indicated in Figures 9 and 11. From Eqs. (9) and (10), one can find that the strain increment under one loading cycle is dependent on the dislocation density ρ ; based on this, the dislocation density ρ was estimated by using the experimental results of $T = 100$ and 500 s and δD^d was then determined from Eq. (8). δD^{gb} was determined by referring to previous work (Cole 1995) because the grain boundary relaxation strength could be reasonably assumed constant for the ice material of interest here, and its effect on inelastic behavior of ice was significantly less than the dislocation mechanism. The values determined for the parameters are tabulated in Table 4. Subsequently, the model based on these parameter values was applied to predict the test results for other loading periods. An example of the comparison of experimental and modeling results is presented in Figure 12, in which the steady-state strain curves from all dry experiments on the 5-ppt-saline ice specimen are accompanied by the simulated ones.

Figure 12 shows that the modeled strain records compare well with those from the experiments with period $T = 1, 5$ and 1000 s. The model reproduced the steady-state strain response of the specimens very well for all tested frequencies. Figure 13 presents the stress-strain hysteresis loops from the same experiments together with those produced by the model. The hysteresis loops generated by using the model are very similar to those from the experiments. The loop area increases with T in both the experiments and simulations.

For assessing the model in more detail, the values of EDD and EDR derived using it are given in Tables 5 and 6, respectively, and moreover, compared with the data from all the experiments (the test matrix is given in Table 1).

Tables 5 and 6 indicate that the model predicts well the values of EDD and EDR for all cyclic loading periods

294 studied here. In general, the error in the predicted EDD and EDR values are within 20%, with the exception of
295 only few cases. No obvious trend between the magnitude of error and loading period or experiment type was
296 observed. Note that for a given ice specimen, one dislocation density value adequately models the steady-state
297 strain responses and energy dissipation values in tests conducted with different frequencies. The value of
298 dislocation density, thus, remained constant through the cyclic loading.
299

300 **4.3 Further validation**

301 The above results show that the model can yield satisfactory predictions on the viscous and anelastic behavior of
302 both dry and floating specimens. One may argue that the good agreement between the model predictions and the
303 experimental results only indicates the capability of the model to predict the results for the experiments with the
304 same stress levels as those used to calibrate the model parameters. To check whether the model can predict the
305 results of the experiments with different stress levels than those above, additional experiments were performed on
306 specimen Dry-5ppt-1 with higher stress (0.1–0.3 MPa) and on specimen Floating-7ppt-1 with lower stress (0.005–
307 0.085 MPa) (Nominal cyclic stress of 0.005–0.085 MPa is low, but the setup could achieve it: With the accuracy
308 of the system, the actual stress applied to the specimen was 0.005 (± 0.001)–0.085 (± 0.003) MPa). The model was
309 then used to determine the strain response and energy dissipation in these tests using the parameterization based
310 on the experiments of Section 3 (Table 4).

311 Figure 14 compares the stress-strain hysteresis loops obtained in the supplementary experiments with the
312 predictions yielded from the model. Good agreement is observed between the predicted and measured hysteresis
313 loops. Again, the relative errors in the EDD and EDR values are found to be less than 20% for most data sets. The
314 model is, indeed, capable of predicting the deformation of saline ice in a dry environment or when floating in water
315 irrespective of the stress level (given that the stress levels are moderate and do not cause an increase in dislocation
316 density during deformation). The applicability of the model is highlighted by the fact that once the model
317 parameters are calibrated through benchmark experiments (the elastic modulus and dislocation density in the
318 present case), it yields sound predictions for the experiments conducted with other stress levels.

319 **5 Discussion**

320 Although past laboratory-scale work has provided insight into the mechanical behavior of sea ice, the work has
321 been mostly performed using relatively cold, dry and isothermal specimens. The results above indicate that more
322 attention should be paid to the mechanical behavior of relatively warm, floating ice with a naturally occurring
323 temperature gradient. Here efforts were made to develop a relatively low-cost, convenient and useful approach for

324 laboratory-scale floating ice experiments and for preparing small-scale, saline columnar ice specimens. The thin
325 sections (Figures 4 and 5) indicated that the measures taken on the ice production guaranteed the generation of
326 non-oriented columnar ice. Moreover, the thin sections showed that the molds used for specimen preparation do
327 not influence the columnar ice microstructure. This is encouraging, as molds are not often incorporated into
328 growing sheets of non-oriented columnar ice. The use of molds in this way significantly simplified specimen
329 preparation and resulted in accurate dimensions. The molds are especially effective in the experiments on floating
330 ice specimens: The specimens thus produced have proper dimensions, require no cutting, have a realistic
331 temperature gradient and can be quickly transferred to the test basin, so brine loss is minimized.

332 The results above are in qualitative agreement with what would be expected for floating ice, as for example,
333 floating specimens having through thickness thermal gradient and mean temperature of -2.5°C exhibit lower
334 modulus and more pronounced inelastic deformation in comparison with dry specimens at -10°C , as would be
335 expected based on full-scale observations on the effect of temperature on this property (Timco and Weeks 2010;
336 Cole 2020). This gives confidence on the methods employed in the production and mechanical testing of the
337 specimens. Further, the good agreement between the results for floating ice and the corresponding model
338 predictions show quantitative validity of the approach taken here. All-in-all, the results suggest that the chosen
339 experimental techniques (including the loading system, the strain measurement scheme, the data acquisition
340 system and settings) worked well and provided useful results for the analysis. An exception is some of the 1-
341 second-period experiments, which yielded strain responses with unexpected features; this is because the hysteresis
342 loop areas are very small in size, making accurate measurements with the used set-up challenging. This could be
343 circumvented in the future experiments by using techniques and devices with even higher precision and setting a
344 higher sampling rate of data acquisition. The methods proposed in this study to conduct laboratory experiments
345 on floating ice experiments are practical and can provide a convenient approach for relatively low-cost
346 experimentation on floating ice.

347 The laboratory work here not only demonstrated the availability of the proposed experimental methods, but also
348 contributes to the understanding of the constitutive behavior of ice. A common trend in developing material models
349 is to ensure they have a solid physical basis, that is, that they are based on an understanding of the physical
350 processes that underlie the mechanical phenomena of interest. Above we used one such physically-based model
351 introduced by Cole (1995). Earlier work, which has been based on the experiments resembling the dry experiments
352 here, has shown that the model is capable of predicting the inelastic deformation of sea ice via dislocation-based
353 mechanisms and is able to estimate the effective dislocation density in ice from experimental results. Here the
354 model was successfully validated against the results from the floating ice experiments. Moreover, the results

355 indicated that once the constant dislocation density value of the specimens was determined, the model adequately
356 predicted the steady-stage deformation for the cyclic loading experiments conducted with different frequencies
357 and stress levels. Even if the use of floating specimens could be considered to only address the temperature profiles
358 of in-situ floating ice (with some other environmental conditions of natural ice floes ignored), the above results
359 bring confidence to the model and demonstrate its potential in modeling practical applications involving ice in
360 such conditions, especially considering that some research has been launched to devote to a numerical
361 implementation of the model (O'Connor et al., 2020).

362 The good agreement between the experimental and modeling results also motivates discussion on the parameter
363 values in Table 4. Expectedly, the floating ice specimens have lower unrelaxed moduli than the dry specimen. For
364 the 5-ppt and 7-ppt-saline ice, the average elastic modulus of the floating specimens is 66% and 55% lower than
365 that of the dry specimens, respectively. In the dry experiments, the isothermal 7-ppt-saline ice has a 31% lower
366 average elastic modulus than the 5-ppt-saline ice. In the floating ice experiments, the 7-ppt-saline specimen still
367 has a lower average elastic modulus than the 5-ppt-saline specimen, but the difference, 8%, is not as prominent as
368 in the dry experiments. **Thus, the fact that the floating ice had a realistic temperature profile had a larger influence**
369 **on the elastic modulus of ice than the variation of the ice salinities studied here.**

370 Table 4 also indicates that the dislocation densities determined for the ice specimens were on the order of $\sim 10^8$ –
371 10^{10} m^{-2} , and thus were in good agreement with values in the 10^9 m^{-2} order of magnitude given by Cole (1995).
372 Moreover, the dislocation density of the floating ice was approximately one order of magnitude greater than that
373 of the dry specimen. Note that there is precedent showing the dislocation density of ice increasing with temperature
374 (Cole and Durell, 2001; Cole, 2020). The same trend is seen here when the experiments change from dry specimens
375 (-10°C) to relatively warm, floating, ones. In addition, the earlier work cited has shown that the dislocation density
376 increases with the salinity. Therefore, the calculated dislocation densities make sense physically and are generally
377 in line with expectations.

378 Specimens originating from two different ice sheets were tested. Table 4 shows that for a given set of conditions,
379 the elastic modulus of the specimens showed only small variations from one sheet to another. Compared with the
380 elastic modulus, the relative change in dislocation density was fairly large, which may be due to heterogeneity of
381 ice. A similar degree of change in dislocation density was also reported by Cole and Durell (2001) related to dry,
382 isothermal, ice specimens. As for the strength of the grain boundary relaxation, its value was taken as $2 (\pm 1) \times 10^$
383 $^{10} \text{ Pa}^{-1}$ for all specimens since variations in grain size among the ice specimens was small. Thus, here the main
384 quantity to be determined from the experimental results for studying anelastic strain response of the specimens
385 was the dislocation density. It was also found that for relatively high loading frequency (for example, 1 Hz used

386 here), the modeled strain behavior was dominated by the un-relaxed modulus E_0 , not sensitive to the dislocation
387 density or the strength of grain boundary relaxation. However, for low-frequency (0.001 Hz) cyclic loading, the
388 modeled specimen deformation was very sensitive to the dislocation density.

389 **The difference in the mechanical behavior between the floating and dry specimens has been mainly** attributed to
390 temperature (Golden et al., 2007). Moreover, the specimens harvested from floating ice sheets lose brine once
391 removed from the sheet; warm ice in particular can lose a significant amount of brine which could significantly
392 alter the mechanical properties in subsequent experiments. In addition, some remaining brine (for example, some
393 of those in capillary brine channels) must freeze during the storage process of dry specimens; this may as well lead
394 to some difference in the macroscopic mechanical behavior (for example, in elastic modulus) of dry and floating
395 specimens (Marchenko and Lishman, 2017; Eicken, 1992; Jones et al., 2012; Gough et al., 2012). The methodology
396 developed in the present effort avoids such problems and is expected to produce more realistic mechanical behavior,
397 particularly when interest centers on behavior at relatively warm temperatures where brine drainage is extensive.
398 The analysis and modeling indicated that the physical mechanisms of deformation in both the warmer, floating
399 specimens and the colder dry specimens were essentially the same. Warmer saline ice had a smaller modulus due
400 to its higher liquid brine volume, which necessarily decreases the volume of the solid ice matrix (thereby reducing
401 the bulk elastic modulus) and there is a pronounced increase in effective dislocation density with increasing
402 temperature (Cole and Durell, 2001; Timco and Weeks, 2010; Cole, 2020). **Thus, according to Eq. (10), although**
403 **the differences in ice temperature between the floating and dry experiments appear to result in an approximately**
404 **two-fold difference in the viscous component of strain, ϵ_v , this does not mean that the temperature will make the**
405 **viscous strain component of the floating ice only twice that of the dry ice. For example, the overall increase in**
406 **strain for specimen Floating-5ppt-1 is much higher (fifteen times more) than that for specimen Dry-5ppt-1. This**
407 **is mainly due to the aforementioned increase in effective dislocation density with increasing temperature (Cole**
408 **and Durell, 2001; Cole, 2020).**

409 **6 Conclusions**

410 Equipment and methods were developed to conduct laboratory experiments to examine the mechanical properties
411 of floating saline ice specimens with a naturally occurring temperature gradient. In this initial effort, we examined
412 the strain response of floating saline ice under cyclic compressive stresses and conducted reference experiments
413 under dry, isothermal conditions. The experiments examined specimens having one of two nominal salinities (5
414 and 7 ppt), cyclic loading frequencies from 10^{-3} to 1 Hz were applied and two levels of cyclic stress were applied.

415 The experimental results compared favorably with the theoretical predictions obtained using a physically based
416 constitutive model for saline ice. Given the limitations of the experiments program, the following conclusions can
417 be drawn.

418 Equipment and methods:

419 1. Groups of unaligned, columnar grained saline ice specimens can be produced simultaneously in the
420 laboratory using floating molds, and the presence of the molds has no observable effect on their
421 microstructure.

422 2. The use of molds produced specimens that could be placed directly in the mechanical testing fixture, which
423 for the case of floating ice experiments, provided a way to maintain a realistic temperature gradient during
424 subsequent experimentation.

425 3. The experimental apparatus, which employed an electrohydraulic actuator and a saline water tank placed
426 in a cold room, provided a way to apply in-plane loads to floating ice specimens and successfully produced
427 monotonic and cyclic loading waveforms employed in more conventional systems.

428 Constitutive modeling:

429 4. The dislocation mechanics of the model employed in the analysis can reproduce well the strain response
430 and energy dissipation of saline ice subjected to cyclic loading for floating ice or dry specimens, and for the
431 observed ice salinities. The results show that the prediction errors of the energy density dissipation and the
432 energy release rate are within $\approx 20\%$.

433 5. For either dry or floating specimens, the higher the salinity of ice, the lower the modulus (E_0) and the larger
434 the dislocation density (ρ). In addition, E_0 is much higher and ρ is far smaller for the dry specimens than for
435 the floating specimens, provided other experimental variables are consistent.

436 This work makes it clear that the mechanical behavior of floating specimens of saline ice can be examined in the
437 laboratory under a reasonable approximation of in-situ conditions and with good efficiency. This capability opens
438 the door to more sophisticated experimental work on saline ice under more realistic environmental conditions than
439 previously possible.

440 **Financial support:** The authors are grateful for the financial support from the Academy of Finland through the
441 project (309830) Ice Block Breakage: Experiments and Simulations (ICEBES).

442 **Acknowledgments:** The authors thank the help from the technical staff of Aalto University Department of
443 Mechanical Engineering, and especially, from Kari Kantola and Veijo Laukkanen.

444 **Author contributions:** AP, MW and DMC designed the study. MW and MP performed the experiments. MW,
445 AP and DMC contributed to the interpretation of the results. MW, AP and DMC drafted the paper. All authors
446 commented on the text.

447 **Code and data availability:** The code used for material modeling is written in MATLAB. Scripts used for analysis
448 and more detailed information of the experimental results are available from the authors upon request.

449 **Competing interests:** The authors declare that they have no conflict of interest.

450 **References**

- 451 Blockley, E. W. and Peterson, K. A.: Improving Met Office seasonal predictions of Arctic sea ice using assimilation
452 of CryoSat-2 thickness, *The Cryosphere*, 12, 3419–3438, <https://doi.org/10.5194/tc-12-3419-2018>, 2018.
- 453 Boe, J. L., Hall, A., and Qu X.: September sea-ice cover in the Arctic Ocean projected to vanish by 2100, *Nat.*
454 *Geosci.*, 2, 341–343, doi:10.1038/ngeo467, 2009.
- 455 Bond, P. E. and Langhorne, P. J.: Fatigue behavior of cantilever beams of saline ice, *J. Cold Reg. Eng.*, 11, 99–
456 112, [https://doi.org/10.1061/\(ASCE\)0887-381X\(1997\)11:2\(99\)](https://doi.org/10.1061/(ASCE)0887-381X(1997)11:2(99)), 1997.
- 457 Cheng, S., Tsarau, A., Evers, K. U., and Shen, H.: Floe size effect on gravity wave propagation through ice covers,
458 *J. Geophys. Res.-Oceans*, 124, 320–334, <https://doi.org/10.1029/2018JC014094>, 2019.
- 459 Cole, D. M.: Reversed direct-stress testing of ice: Initial experimental results and analysis. *Cold Reg. Sci. Technol.*,
460 18, 303–321, [https://doi.org/10.1016/0165-232X\(90\)90027-T](https://doi.org/10.1016/0165-232X(90)90027-T), 1990.
- 461 Cole, D. M.: A model for the anelastic straining of saline ice subjected to cyclic loading, *Philos. Mag. A*, 72, 231–
462 248, <https://doi.org/10.1080/01418619508239592>, 1995.
- 463 Cole, D. M.: On the physical basis for the creep of ice: the high temperature regime. *J. Glaciol.*, 1–14.
464 <https://doi.org/10.1017/jog.2020.15>, 2020.
- 465 Cole, D. M. and Dempsey, J. P.: Influence of scale on the constitutive behavior of sea ice, In: *International Union*
466 *of Theoretical and Applied Mechanics Symposium on Scaling Laws in Ice Mechanics and Ice Dynamics*,
467 pp. 251–264. Kluwer, Dordrecht, https://doi.org/10.1007/978-94-015-9735-7_22, 2001.
- 468 Cole, D. M. and Dempsey, J. P.: In situ sea ice experiments in McMurdo Sound: cyclic loading, fracture, and
469 acoustic emissions, *J. Cold Reg. Eng.*, 18, 155–174, [https://doi.org/10.1061/\(ASCE\)0887-](https://doi.org/10.1061/(ASCE)0887-381X(2004)18:4(155))
470 [381X\(2004\)18:4\(155\)](https://doi.org/10.1061/(ASCE)0887-381X(2004)18:4(155)), 2004.
- 471 Cole, D. M. and Durell, G. D.: The cyclic loading of saline ice, *Philos. Mag. A*, 72, 209–229,
472 <https://doi.org/10.1080/01418619508239591>, 1995.

473 Cole, D. M. and Durell, G. D.: A dislocation-based analysis of strain history effects in ice, *Philos. Mag. A*, 81,
474 1849–1872, <https://doi.org/10.1080/01418610108216640>, 2001.

475 Cole, D. M., Johnson, R. A., and Durell, G. D.: Cyclic loading and creep response of aligned first-year sea ice, *J.*
476 *Geophys. Res.*, 103, 21,751–21,758S, <https://doi.org/10.1029/98JC01265>, 1998.

477 Dempsey, J. P.: Research trends in ice mechanics, *Int. J. Solids Struct.*, 37, 131–153,
478 [https://doi.org/10.1016/S0020-7683\(99\)00084-0](https://doi.org/10.1016/S0020-7683(99)00084-0), 2000.

479 Dempsey, J. P., Adamson, R. M., and Mulmule. S. V.: Scale effects on the in-situ tensile strength and fracture of
480 ice, Part II: First-year sea ice at Resolute, N.W.T. *Int. J. Fract.*, 95, 347–366,
481 <https://doi.org/10.1023/A:1018650303385>, 1999.

482 Dempsey, J. P., Cole, D. M., and Wang, S.: Tensile fracture of a single crack in first-year sea ice. *Phil. Trans. R.*
483 *Soc. A*, 376, <https://doi.org/10.1098/rsta.2017.0346>, 2018,

484 Eicken, H.: Salinity profiles of Antarctic sea ice: Field data and model results, *J. Geophys. Res.-Oceans*, 97,
485 15,545–15,557, <https://doi.org/10.1029/92JC01588>, 1992.

486 Feltham, D. L.: sea Ice rheology. *Annu. Rev. Fluid Mech.*, 40, 91–112,
487 <https://doi.org/10.1146/annurev.fluid.40.111406.102151>, 2008.

488 Gagne, M. E., Gillett N. P., and Fyfe, J. C.: Observed and simulated changes in Antarctic sea ice extent over the
489 past 50 years, *Geophys. Res. Lett.*, 42, 90–95, <https://doi.org/10.1002/2014GL062231>, 2015.

490 Golden, K. M., Eicken, H., Heaton, A. L., Miner, J., Pringle, D. J., and Zhu, J.: Thermal evolution of permeability
491 and microstructure in sea ice, *Geophys. Res. Lett.*, 34, L16501, <https://doi.org/10.1029/2007GL030447>,
492 2007.

493 Gough, A. J., Mahoney, A. R., Langhorne, P. J., Williams, M. J. M., and Haskell, T. G.: Sea ice salinity and
494 structure: A winter time series of salinity and its distribution, *J. Geophys. Res.-Oceans*, 7, C03008,
495 <https://doi.org/10.1029/2011JC007527>, 2012.

496 Gow, A. J. Crystalline structure of urea ice sheets used in modeling experiments in the CRREL test basin. CRREL
497 report ; 84-24, <https://hdl.handle.net/11681/9553>, 1984.

498 Haskell, T. G., Robinson, W. H., and Langhorne, P. J.: Preliminary results from fatigue tests on in situ sea ice
499 beams, *Cold Reg. Sci. Technol.*, 24, 167–176, [https://doi.org/10.1016/0165-232X\(95\)00015-4](https://doi.org/10.1016/0165-232X(95)00015-4), 1996.

500 Heijkoop, A. N., Nord, T. S., and Høyland, K. V.: Strain-controlled cyclic compression of sea ice. 24th IAHR
501 International Symposium on Ice Vladivostok, Russia, June 4 to 9, 2018.

502 Herman, A., Cheng, S., and Shen, H. H.: Wave energy attenuation in fields of colliding ice floes – Part 1: Discrete-
503 element modelling of dissipation due to ice–water drag, *The Cryosphere*, 13, 2887–2900,
504 <https://doi.org/10.5194/tc-13-2887-2019>, 2019a.

505 Herman, A., Cheng S., and Shen, H. H.: Wave energy attenuation in fields of colliding ice floes – Part 2: A
506 laboratory case study, *The Cryosphere*, 13, 2901–2914, <https://doi.org/10.5194/tc-13-2901-2019>, 2019b.

507 Iliescu, D. and Schulson, E. M.: Brittle compressive failure of ice: monotonic versus cyclic loading, *Acta Mater.*,
508 50, 2163–2172, [https://doi.org/10.1016/S1359-6454\(02\)00060-5](https://doi.org/10.1016/S1359-6454(02)00060-5), 2002.

509 Iliescu, D., Murdza, A., Schulson, E. M., and Renshaw, C. E.: Strengthening ice through cyclic loading, *J. Glaciol.*,
510 63, 663–669, <https://doi.org/10.1017/jog.2017.32>, 2017.

511 Jones, K. A., Ingham, M., and Eicken, H. Modeling the anisotropic brine microstructure in first - year arctic sea
512 ice, *J. Geophys. Res.-Oceans*, 117, C02005, doi:10.1029/2011JC007607, 2012.

513 Kartashkin, B. D.: Experimental studies of the physico-mechanical properties of ice, Tsentra'nyy
514 Aerogidrodinamicheskiy Institut, 1947

515 Kern, S., Lavergne, T., Notz, D., Pedersen, L. T., Tonboe, R. T., Saldo, R., and Sørensen, A. M. D.: Satellite passive
516 microwave sea-ice concentration data set intercomparison: closed ice and ship-based observations, *The*
517 *Cryosphere*, 13, 3261–3307, <https://doi.org/10.5194/tc-13-3261-2019>, 2019.

518 Langway, C. C.: Ice fabrics and the universal stage, Report # 62, CRREL, 1958.

519 Langhorne, P. J., Squire, V. A., Fox, C., and Haskell, T. G.: Break-up of sea ice by ocean waves, *Ann. Glaciol.*, 27,
520 438–442, <https://doi.org/10.3189/S0260305500017869>, 1998.

521 Langhorne, P. J., Hughes, K. G., Gough, A. J., Smith, I. J., Williams, M. J. M., Robinson, N. J., Stevens, C. L.,
522 Rack, W., Price, D., Leonard, G. H., Mahoney, A. R., Haas, C., and Haskell, T. G.: Observed platelet ice
523 distributions in Antarctic sea ice: An index for ocean-ice shelf heat flux, *Geophys. Res. Lett.*, 42, 5442–
524 5451, <https://doi.org/10.1002/2015GL064508>, 2015.

525 Leclair, E. S., Schapery, R. A., and Dempsey, J. P.: A broad-spectrum constitutive modeling technique applied to
526 saline ice, *Int. J. Fract.*, 97, 209–226, <https://doi.org/10.1023/A:1018358923672>, 1999.

527 Li, J., Kohout, A. L., and Shen, H. H.: Comparison of wave propagation through ice covers in calm and storm
528 conditions, *Geophys. Res. Lett.*, 42, 5935–5941, <https://doi.org/10.1002/2015GL064715>, 2015.

529 Li, Z., Riska, K.: Preliminary study of physical and mechanical properties of model ice. Technical Report M-212.
530 Helsinki University of Technology, 1996.

531 Liu, Y., Dai, F., Dong, L., Xu N., and Feng, P.: Experimental investigation on the fatigue mechanical properties of
532 intermittently jointed rock models under cyclic uniaxial compression with different loading parameters,
533 *Rock Mech. Rock Eng.*, 51, 47–68, <https://doi.org/10.1007/s00603-017-1327-7>, 2018.

534 Liu, Y., Dai, F., Fan, P., Xu, N., and Dong, L.: Experimental investigation of the influence of joint geometric
535 configurations on the mechanical properties of intermittent jointed rock models under cyclic uniaxial
536 compression, *Rock Mech. Rock Eng.*, 50, 453–1471, <https://doi.org/10.1007/s00603-017-1190-6>, 2017

537 Lu, W. and Løset, S.: Parallel channels' fracturing mechanism during ice management operations. Part II:
538 Experiment, *Cold Reg. Sci. Technol.*, 156, 117–133, <https://doi.org/10.1016/j.coldregions.2018.07.011>,
539 2018.

540 Lu, W., Lubbad, R., Shestov, A., and Løset, S.: Parallel channels' fracturing mechanism during ice management
541 operations, Part I: Theory. *Cold Reg. Sci. Technol.*, 156, 102–116,
542 <https://doi.org/10.1016/j.coldregions.2018.07.010>, 2018.

543 Marchenko, A. and Lishman, B.: The influence of closed brine pockets and permeable brine channels on the
544 thermo-elastic properties of saline ice. *Phil. Trans. R. Soc. A*, 375, 20150351,
545 <http://dx.doi.org/10.1098/rsta.2015.0351>, 2017.

546 Mellor, M. and Cole, D.: Cyclic loading and fatigue in ice. *Cold Reg. Sci. Technol.*, 4, 41-53,
547 [https://doi.org/10.1016/0165-232X\(81\)90029-X](https://doi.org/10.1016/0165-232X(81)90029-X), 1981.

548 Murdza, A., Schulson, E. M., and Renshaw, C. E.: Hysteretic behavior of freshwater ice under cyclic loading: A
549 preliminary results. 24th IAHR International Symposium on Ice. Vladivostok, 185–192, 2018.

550 Murdza, A., Schulson, E. M., and Renshaw, C. E.: The effect of cyclic loading on the flexural strength of columnar
551 freshwater ice. In the Proceedings of the 25th International Conference on Port and Ocean Engineering
552 under Arctic Conditions (POAC'19). Electronic publication, 2019.

553 O'Connor DT, West BA, Haehnel RB, Asenath-Smith E, Cole D. A viscoelastic integral formulation and numerical
554 implementation of an isotropic constitutive model of saline ice, *Cold Reg. Sci. Technol.*, 171, 102983,
555 <https://doi.org/10.1016/j.coldregions.2019.102983>, 2020.

556 Polojärvi, A., Tuhkuri, J., and Pustogvar, A. DEM simulations of direct shear box experiments of ice rubble: Force
557 chains and peak loads, *Cold Reg. Sci. Technol.*, 116, 12–23,
558 <https://doi.org/10.1016/j.coldregions.2015.03.011>, 2015.

559 Ranta, J., Polojärvi, A., and Tuhkuri, J. The statistical analysis of peak ice loads in a simulated ice-structure
560 interaction process, *Cold Reg. Sci. Technol.*, 133, 46–55,
561 <https://doi.org/10.1016/j.coldregions.2016.10.002>, 2017.

562 Ranta, J., Polojärvi, A., and Tuhkuri, J.: Ice loads on inclined marine structures - Virtual experiments on ice failure
563 process evolution, *Mar. Struct.*, 57, 72–86, <https://doi.org/10.1016/j.marstruc.2017.09.004>, 2018a.

564 Ranta, J., Polojärvi, A., and Tuhkuri, J.: Limit mechanisms for ice loads on inclined structures: Buckling, *Cold*
565 *Reg. Sci. Technol.*, 147, 34–44, <https://doi.org/10.1016/j.coldregions.2017.12.009>, 2018b.

566 Reistad, M., Breivik, Ø., Haakenstad, H., Aarnes, O. J., Furevik, B. R., and Bidlot, J. R.: A high-resolution hindcast
567 of wind and waves for the North Sea, the Norwegian Sea, and the Barents Sea, *J. Geophys. Res.*, 116,
568 C05019, <https://doi.org/10.1029/2010JC006402>, 2011.

569 Ridley, J. K. and Blockley, E. W.: Brief communication: Solar radiation management not as effective as CO₂
570 mitigation for Arctic sea ice loss in hitting the 1.5 and 2 °C COP climate targets, *The Cryosphere*, 12,
571 3355–3360, <https://doi.org/10.5194/tc-12-3355-2018>, 2018.

572 Schulson, E. M. and Duval, P.: *Creep and fracture of ice*, Cambridge University Press, Cambridge, 2009.

573 Serreze, M. C. and Stroeve, J.: Arctic sea ice trends, variability and implications for seasonal ice forecasting, *Phil.*
574 *Trans. R. Soc. A*, 373, 20140159, <http://dx.doi.org/10.1098/rsta.2014.0159>, 2015.

575 Smith, I. J., Gough, A. J., Langhorne, P. J., Mahoney, A. R., Leonard, G. H., Van Hale, R., Jendersie, S., and
576 Haskell, T. G.: First-year land-fast Antarctic sea ice as an archive of ice shelf meltwater fluxes, *Cold*
577 *Reg. Sci. Technol.*, 113, 63–70, <https://doi.org/10.1016/j.coldregions.2015.01.007>, 2015.

578 Tabata, T. and Nohguchi, Y.: Failure of sea ice by repeated compression, In: Tryde P. (eds) *Physics and Mechanics*
579 *of Ice*, International Union of Theoretical and Applied Mechanics, Springer, Berlin, Heidelberg, 351–362,
580 https://doi.org/10.1007/978-3-642-81434-1_25, 1980.

581 Timco, G. W. and Weeks, W. F.: A review of the engineering properties of sea ice, *Cold Reg. Sci. Technol.*, 60,
582 107–129, <https://doi.org/10.1016/j.coldregions.2009.10.003>, 2010.

583 Tuhkuri, J. and Polojärvi, A.: A review of discrete element simulation of ice-structure interaction, *Phil. Trans. R.*
584 *Soc. A*, 376, 20170335, <http://dx.doi.org/10.1098/rsta.2017.0335>, 2018.

585 Vincent, M. R. and Dempsey, J. P.: Servo-hydraulic pin loading device (HPLD) for in situ ice testing, *J. Cold Reg.*
586 *Eng.*, 13, 21–36, [https://doi.org/10.1061/\(ASCE\)0887-381X\(1999\)13:1\(21\)](https://doi.org/10.1061/(ASCE)0887-381X(1999)13:1(21)), 1999.

587 Voermans, J. J., Babanin, A. V., Thomson, J., Smith, M. M., and Shen, H. H.: Wave attenuation by sea ice
588 turbulence, *Geophys. Res. Lett.*, 46, 6796–6803, <https://doi.org/10.1029/2019GL082945>, 2019.

589 Weber, L. J. and Nixon, W. A.: Hysteretic behavior in ice under fatigue loading. *Proceedings of the 15th*
590 *International Conference on Offshore Mechanics and Arctic Engineering*. 75–82, 1996.

591 Wongpan, P., Hughes, K. G., Langhorne, P. J., and Smith, I. J.: Brine Convection, temperature fluctuations, and
592 permeability in winter Antarctic land-fast sea ice, 123, 216–230, <https://doi.org/10.1002/2017JC012999>,
593 2018.

594 Zijlema, M., Vledder, G. Ph. van, and Holthuijsen, L. H.: Bottom friction and wind drag for wave models, *Coast.*
595 *Eng.*, 65, 19–26, <https://doi.org/10.1016/j.coastaleng.2012.03.002>, 2012.

596

597

598 **Table 1 The test matrix of this experimental campaign. The campaign included two test types, two ice**
 599 **salinities, six periods and two test-type-dependent load levels. For each case, two specimens harvested from**
 600 **two ice sheets were tested.**

Case	Specimen no.	Ice salinity (ppt)	Dry/Floating	Average ice temperature (°C)	Period (s)	Cyclic compressive Stresses (MPa)
I	Dry-5ppt-1, Dry-5ppt-2	5	Dry	-10	1, 5, 10, 100, 500, 1000	0.08–0.25
II	Dry-7ppt-1, Dry-7ppt-2	7	Dry	-10	1, 5, 10, 100, 500, 1000	0.08–0.25
III	Floating-5ppt-1, Floating-5ppt-2	5	Floating	-2.5	1, 5, 10, 100, 500, 1000	0.04–0.12
IV	Floating-7ppt-1, Floating-7ppt-2	7	Floating	-2.5	1, 5, 10, 100, 500, 1000	0.04–0.12

601

602 **Table 2 The energy density ($J \cdot m^{-3}$) dissipated in a typical loading-unloading cycle of each experiment.**

Specimen no.	Frequency (Hz)				
	0.001	0.002	0.01	0.1	0.2
Dry-5ppt-1	8.83	5.44	2.01	0.67	0.71
Dry-5ppt-2	5.36	2.93	1.57	0.54	0.36
Dry-7ppt-1	14.4	7.16	2.87	0.91	0.66
Dry-7ppt-2	20.8	14.0	7.80	2.49	2.05
Floating-5ppt-1	25.0	15.4	4.78	0.85	0.63
Floating-5ppt-2	28.4	16.2	4.79	0.91	0.54
Floating-7ppt-1	151	67.7	20.2	3.85	2.52
Floating-7ppt-2	63.6	38.3	11.7	2.40	1.63

603

604 **Table 3 The energy dissipation rate (%) in a typical loading-unloading cycle of each experiment.**

Specimen no.	Frequency (Hz)				
	0.001	0.002	0.01	0.1	0.2
Dry-5ppt-1	48.3	40.2	22.0	9.86	9.93
Dry-5ppt-2	35.4	22.7	17.6	8.68	5.50
Dry-7ppt-1	55.6	37.3	21.6	11.0	8.60
Dry-7ppt-2	55.7	44.7	32.3	16.0	14.3
Floating-5ppt-1	89.6	76.1	44.2	15.5	11.8
Floating-5ppt-2	87.7	69.8	39.4	17.4	11.3
Floating-7ppt-1	98.3	91.7	70.5	32.0	25.1
Floating-7ppt-2	88.1	76.0	56.4	26.3	20.2

605
606

Table 4. Values of the model parameters calibrated for simulating the strain response of the ice specimens (in Section 5, these values are discussed and compared to those reported in references).

Specimen no.	Elastic modulus E_0 (GPa)	Dislocation density ρ (m^{-2})	Strength of dislocation relaxation δD^d (Pa^{-1})	Strength of grain boundary δD^{gb} (Pa^{-1})
Dry-5ppt-1	6.0	7.53×10^8	7×10^{-10}	1×10^{-10}
Dry-5ppt-2	5.6	4.31×10^8	4×10^{-10}	1×10^{-10}
Dry-7ppt-1	4.0	1.18×10^9	1.1×10^{-9}	1×10^{-10}
Dry-7ppt-2	4.0	1.83×10^9	1.7×10^{-9}	3×10^{-10}
Floating-5ppt-1	2.0	5.92×10^9	5.5×10^{-9}	3×10^{-10}
Floating-5ppt-2	1.9	6.46×10^9	6×10^{-9}	1×10^{-10}
Floating-7ppt-1	1.9	2.58×10^{10}	2.4×10^{-8}	3×10^{-10}
Floating-7ppt-2	1.7	1.40×10^{10}	1.3×10^{-8}	2×10^{-10}

607
608
609

Table 5. Modeling results of the strain energy density ($\text{J} \cdot \text{m}^{-3}$) dissipated per loading-unloading cycle (the values given in parentheses are error percentages of model predictions relative to experimental results).

Specimen no.	Frequency				
	0.001 Hz	0.002 Hz	0.01 Hz	0.1 Hz	0.2 Hz
Dry-5ppt-1	9.12 (7%)	5.16 (9%)	1.74 (-10%)	0.69 (-9%)	0.68 (-21%)
Dry-5ppt-2	5.22 (-3%)	3.10 (6%)	1.15 (-27%)	0.55 (2%)	0.33 (-8%)
Dry-7ppt-1	15.1 (5%)	8.76 (22%)	2.65 (-8%)	0.86 (-5%)	0.79 (20%)
Dry-7ppt-2	21.9 (-1%)	12.5 (-4%)	6.44 (-9%)	2.00 (-22%)	1.97 (12%)
Floating-5ppt-1	27.0 (8%)	14.9 (-3%)	4.05 (-15%)	0.91 (7%)	0.73 (16%)
Floating-5ppt-2	30.3 (3%)	16.8 (1%)	4.58 (-6%)	0.89 (-17%)	0.61 (-8%)
Floating-7ppt-1	125 (-17%)	68.5 (1%)	18.6 (-8%)	3.79 (-2%)	2.58 (2%)
Floating-7ppt-2	65.4 (-17%)	36.4 (-4%)	10.0 (-21%)	2.18 (10%)	1.73 (13%)

610
611
612
613
614

615

616

Table 6. Modeling results of the strain energy dissipation rate (%) per loading-unloading cycle (the values given in parentheses are error percentages of model predictions relative to experimental results).

Specimen no.	Frequency				
	0.001 Hz	0.002 Hz	0.01 Hz	0.1 Hz	0.2 Hz
Dry-5ppt-1	49.2 (4%)	36.7 (-1%)	18.5 (-13%)	9.43 (-12%)	9.81 (-16%)
Dry-5ppt-2	37.4 (16%)	25.9 (14%)	13.9 (-21%)	7.5 (-5%)	5.70 (12%)
Dry-7ppt-1	53.1 (-1%)	41.3 (-2%)	20.2 (10%)	8.99 (-18%)	8.50 (12%)
Dry-7ppt-2	51.3 (-1%)	38.9 (-2%)	25.7 (10%)	12.6 (-18%)	13.9 (12%)
Floating-5ppt-1	87.8 (-5%)	77.1 (-4%)	40.0 (-15%)	16.0 (3%)	14.0 (3%)
Floating-5ppt-2	91.1 (-1%)	82.0 (6%)	45.1 (-4%)	17.6 (9%)	13.4 (26%)
Floating-7ppt-1	86.4 (-1%)	77.4 (-3%)	59.9 (-10%)	34.0 (13%)	28.2 (17%)
Floating-7ppt-2	94.5 (-1%)	88.3 (-3%)	52.9 (-10%)	23.8 (13%)	20.5 (17%)

617

618

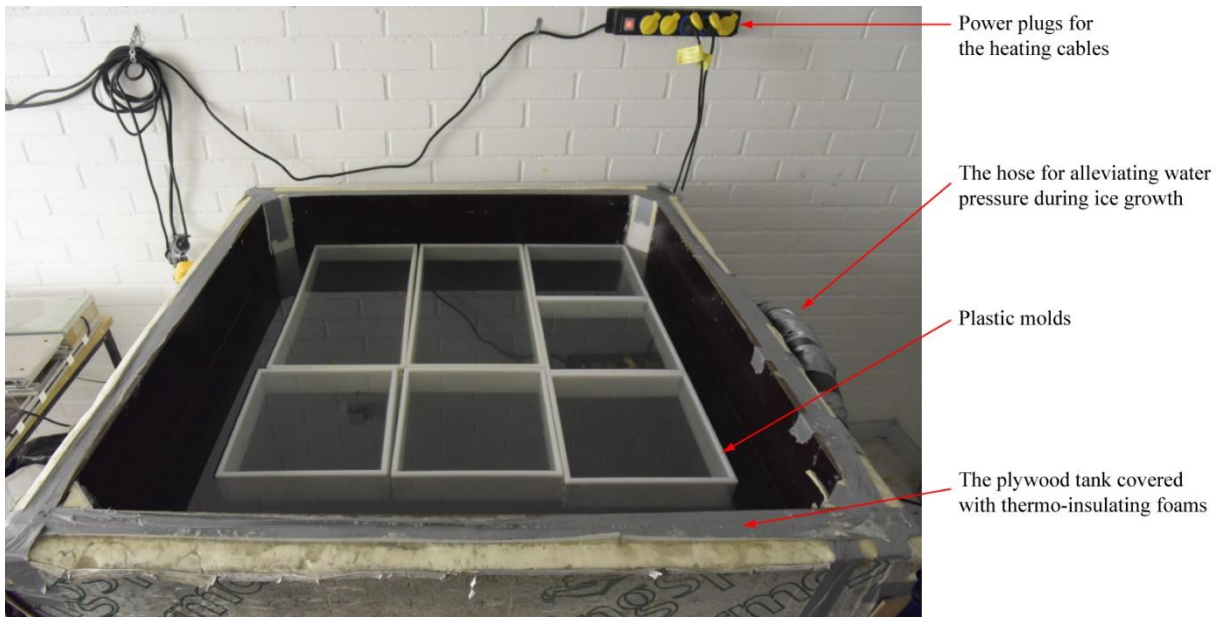

619

Figure 1. The tank made of plywood for growing ice specimens.

620



621

Figure 2. Equipment used in the (a) dry and (b) floating ice experiments. One of the plastic molds used when growing ice is shown in (b). The thin ice cover of the basin, seen in (b), was broken before performing the experiments.

624
625

626

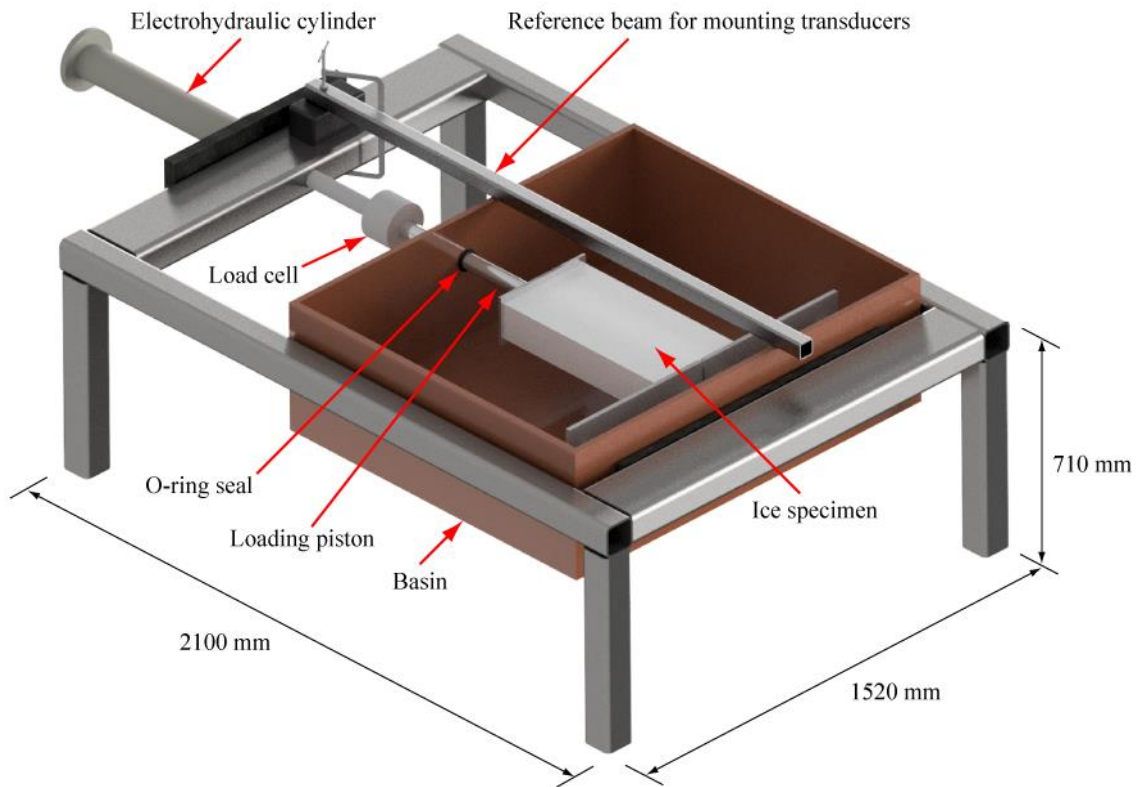

627 **Figure 3. A sketch of the test rig used in the experiments. The inner dimensions of the basin are 1320 mm ×**
628 **1280 mm × 400 mm.**

629

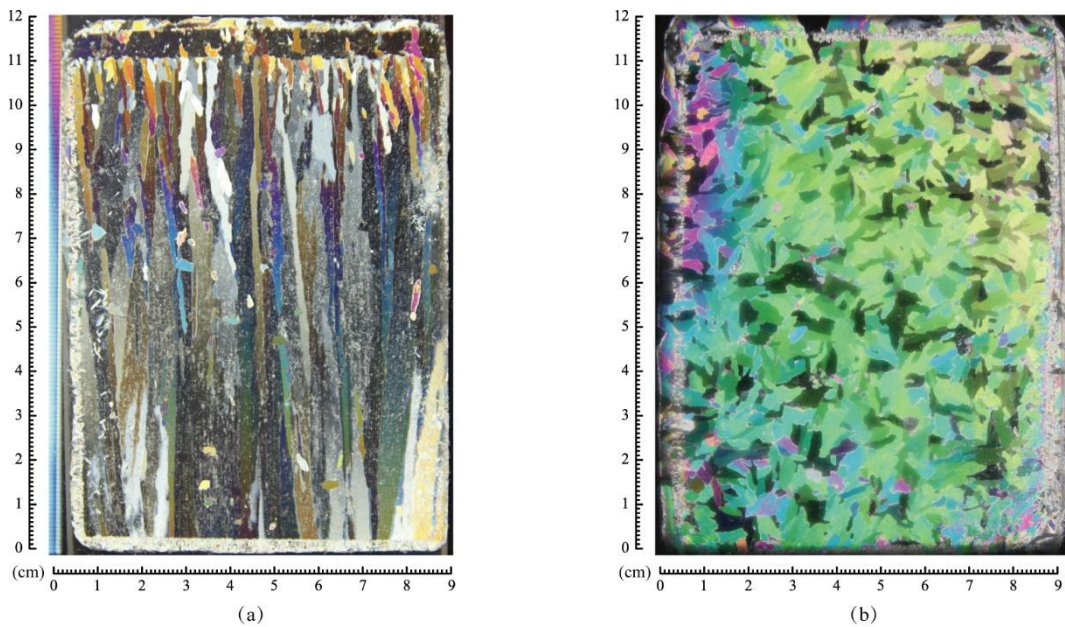

630

631 **Figure 4. One set of thin sections of the ice (salinity: 5 ppt) grown in this experimental campaign: (a) vertical;**
632 **(b) horizontal.**

633

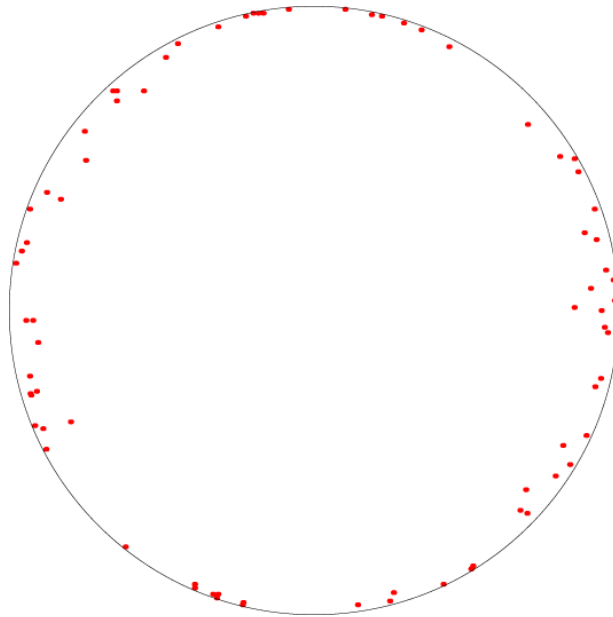

634
635
636
637

Figure 5. A typical Schmidt equal area net pole projection drawn on the basis of grain orientations.

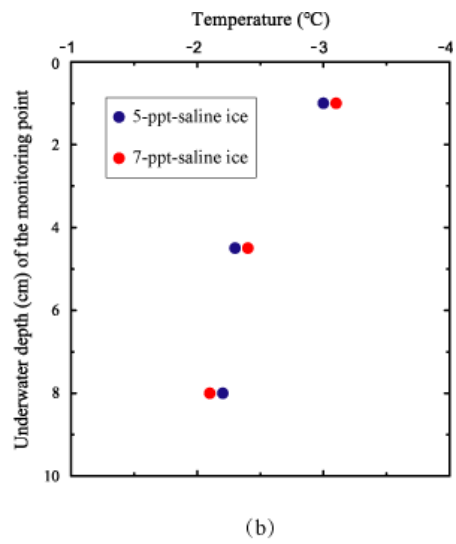
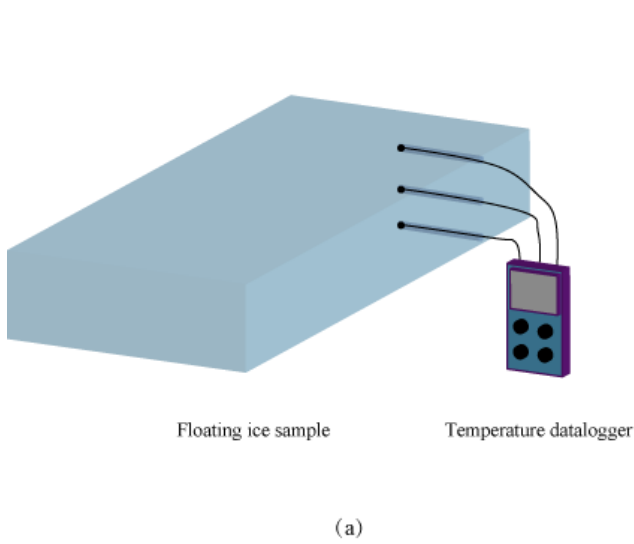

638
639
640
641

Figure 6. Monitoring of the through-thickness thermal gradient of floating ice: (a) a schematic diagram of the arrangement of the temperature probes and (b) the measured through-thickness thermal gradient inside two floating ice specimens.

642

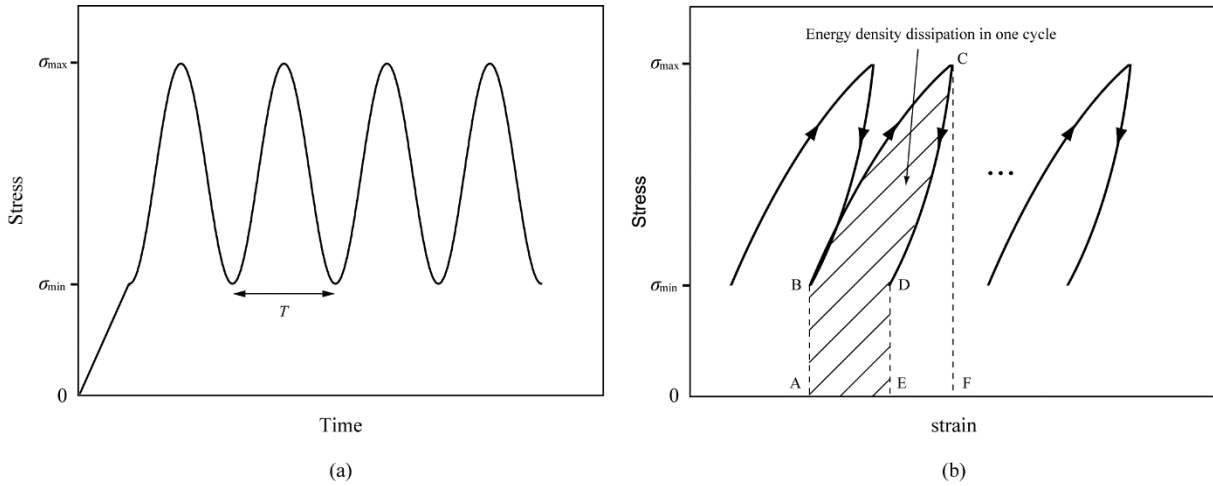

643

644

Figure 7. Schematic diagrams of the cyclic loads: (a) the inputted stress waveform, and (b) the method for calculating the energy density dissipated in one loading cycle (in other words, region ABCDE).

645

646

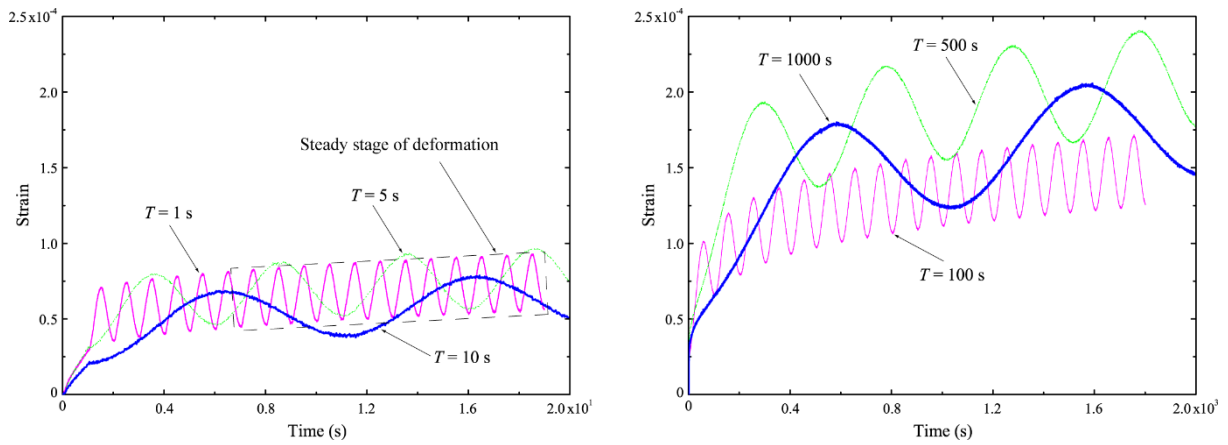

647

648

649

Figure 8. Strain-time curves of specimen Dry-5ppt-1 tested with stresses varying from 0.08 to 0.25 MPa and with the temperature of -10°C.

650

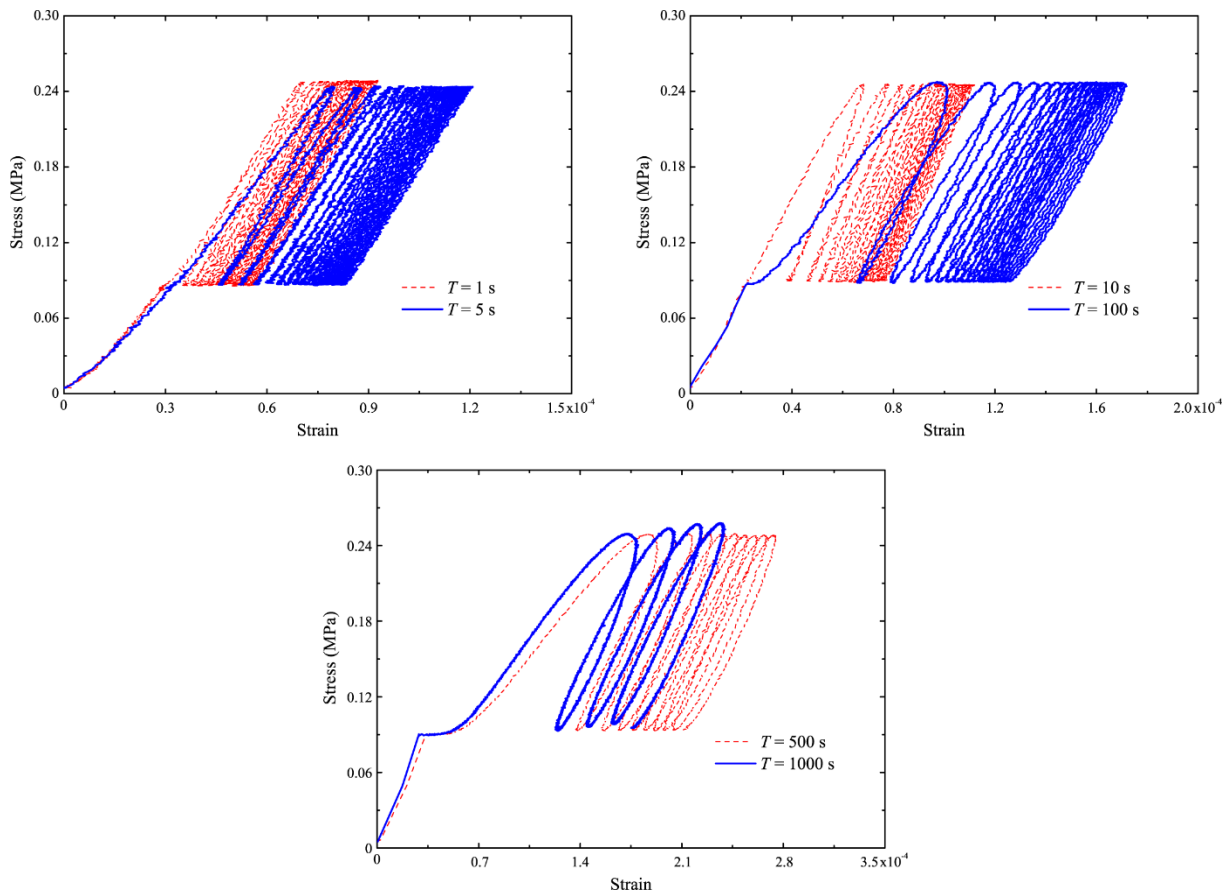

651

652 **Figure 9. Stress-strain curves of specimen Dry-5ppt-1 tested with stresses varying from 0.08 to 0.25 MPa**
653 **and with the temperature of -10°C.**

653

654

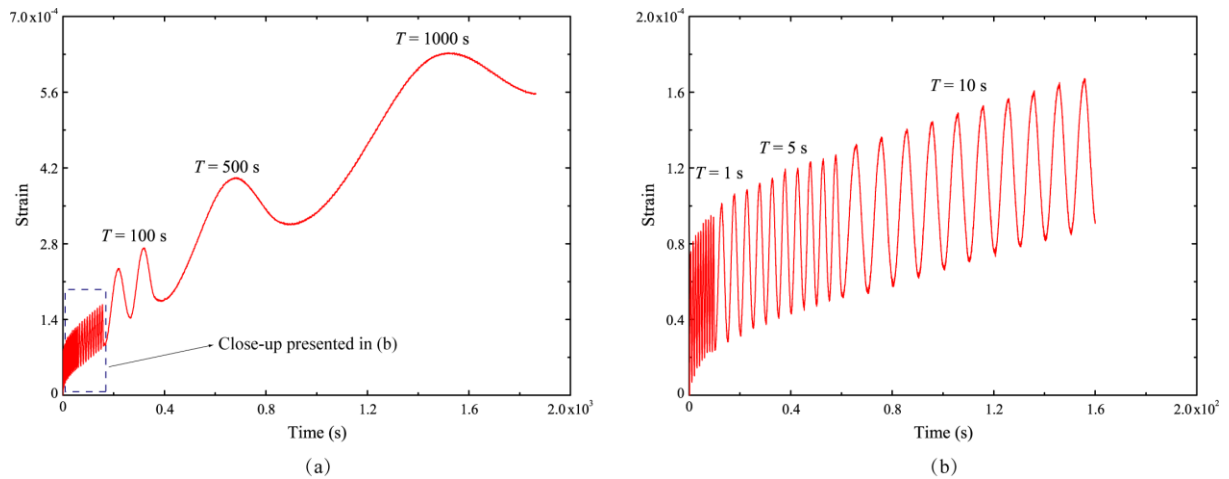

655

656 **Figure 10. Strain response of specimen Floating-5ppt-1 tested with stresses varying from 0.04 to 0.12 MPa**
657 **and with the average temperature of -2.5°C: (a) shows the response for all periods, T , of cyclic loading, while**
658 **(b) presents a close-up showing the cycles for $T = 1, 5$ and 10 s.**

659

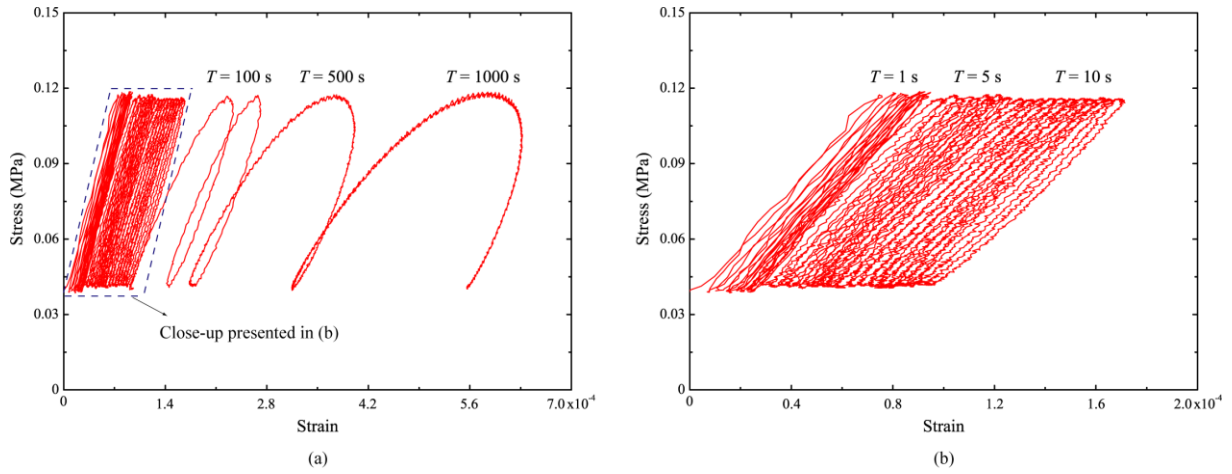

660

661

662

Figure 11. Stress-strain plots of specimen Floating-5ppt-1 tested with stresses varying from 0.04 to 0.12 MPa and with the average temperature of -2.5°C : (a) shows the response for all periods, T , of cyclic loading, while (b) presents a close-up showing the cycles for $T = 1, 5$ and 10 s.

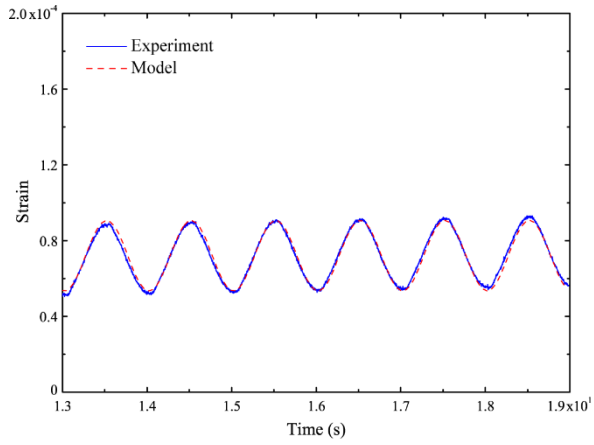

(a) $T = 1$ s

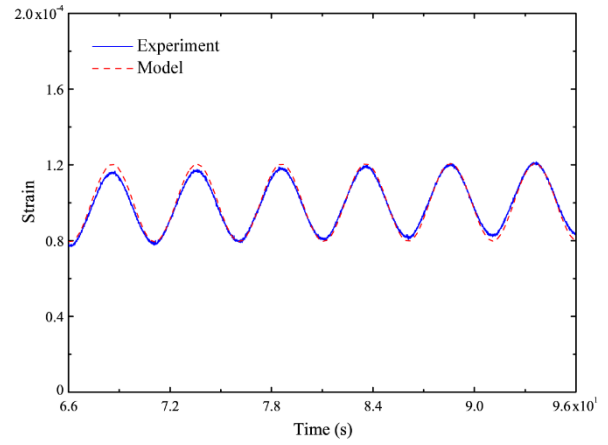

(b) $T = 5$ s

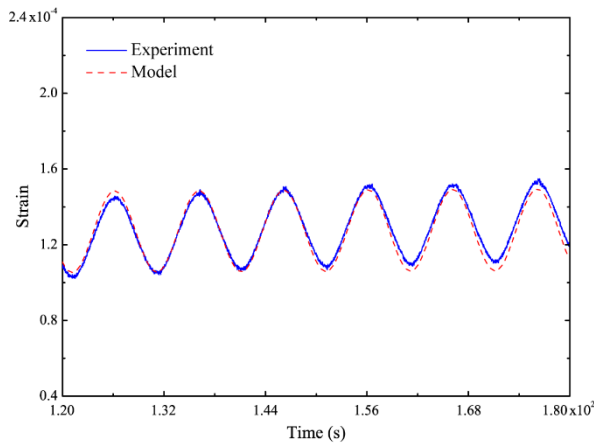

(c) $T = 10$ s

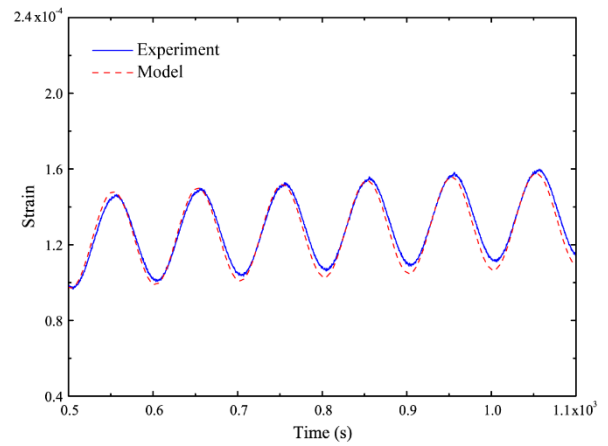

(d) $T = 100$ s

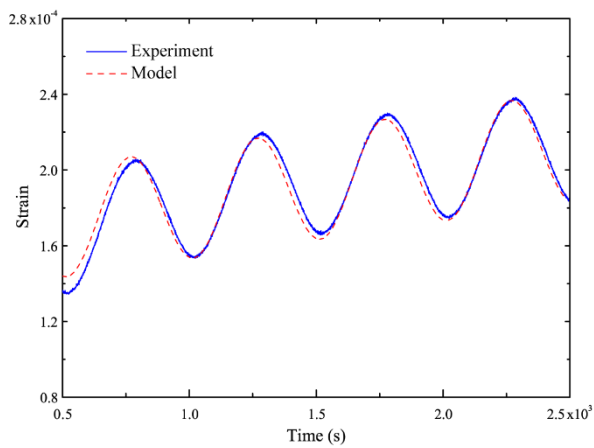

(e) $T = 500$ s

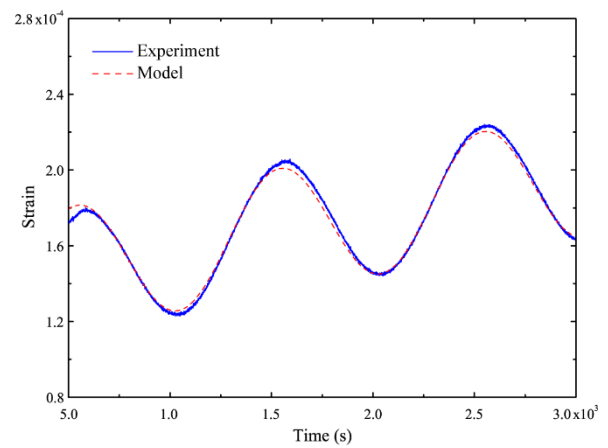

(f) $T = 1000$ s

Figure 12. Comparison between the experimentally measured strain-time curves (in the steady stage) and the results yielded by the physically based model for specimen Dry-5ppt-1 tested with stresses varying from 0.08 to 0.25 MPa and with the temperature of -10°C .

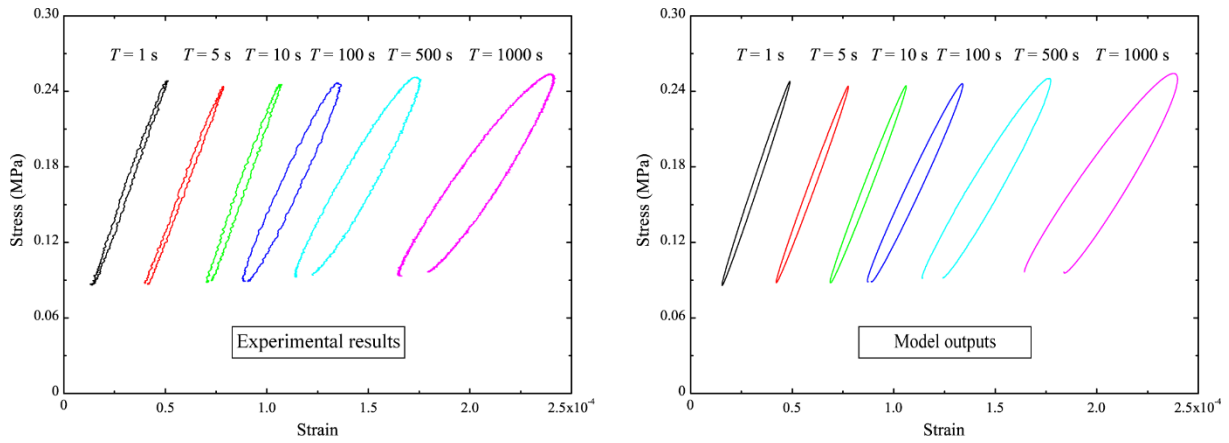

(a)

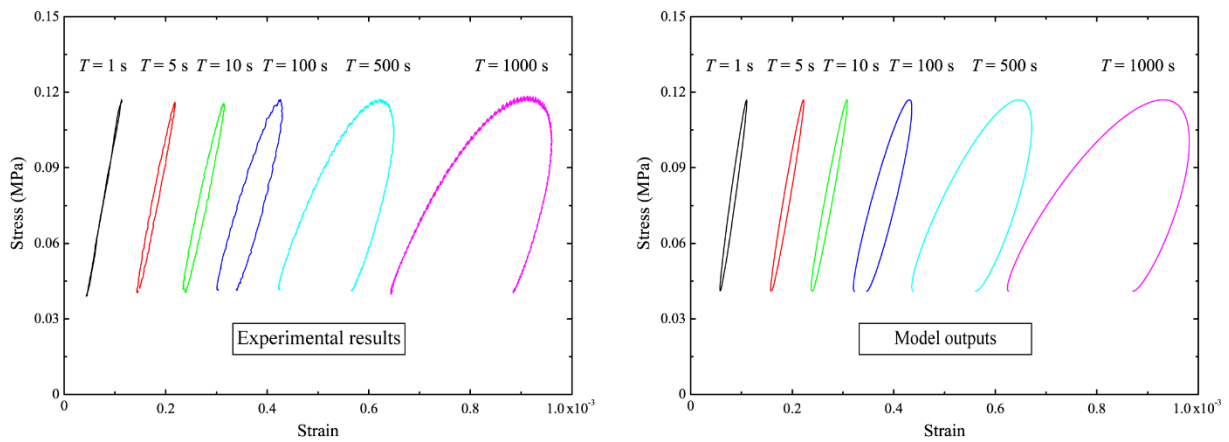

(b)

668

669

670

671

672

673

674

675

Figure 13. Comparison between the steady-state stress-strain hysteresis loop measured in the experiments and that outputted from the model for (a) specimen Dry-5ppt-1 with the temperature of -10°C and (b) specimen Floating-5ppt-1 with the average temperature of -2.5°C (note that, to compare the representative hysteresis loops in all the different-frequency experiments with those outputted by the model in a more concise and intuitive way, the pre-strains before the hysteresis loops drawn here are not equal to the experimental values).

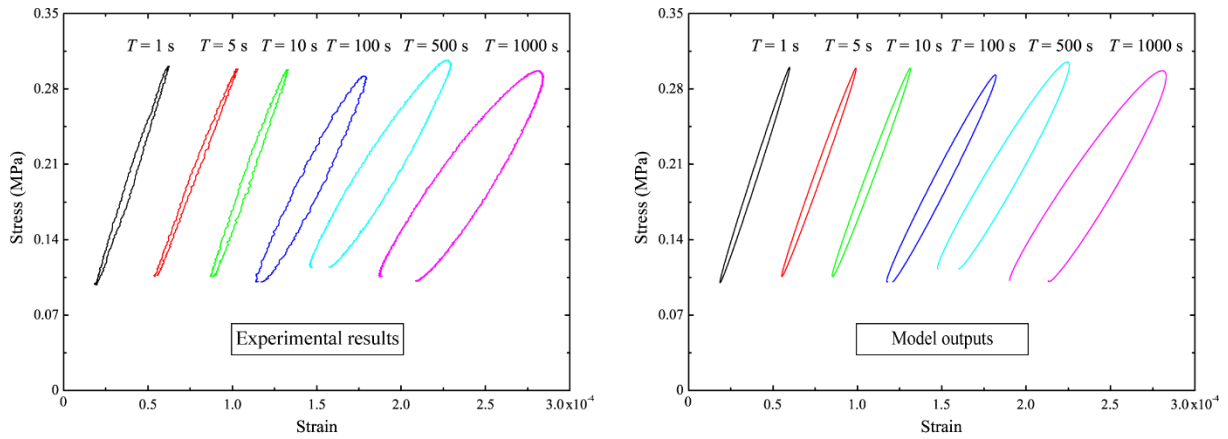

(a)

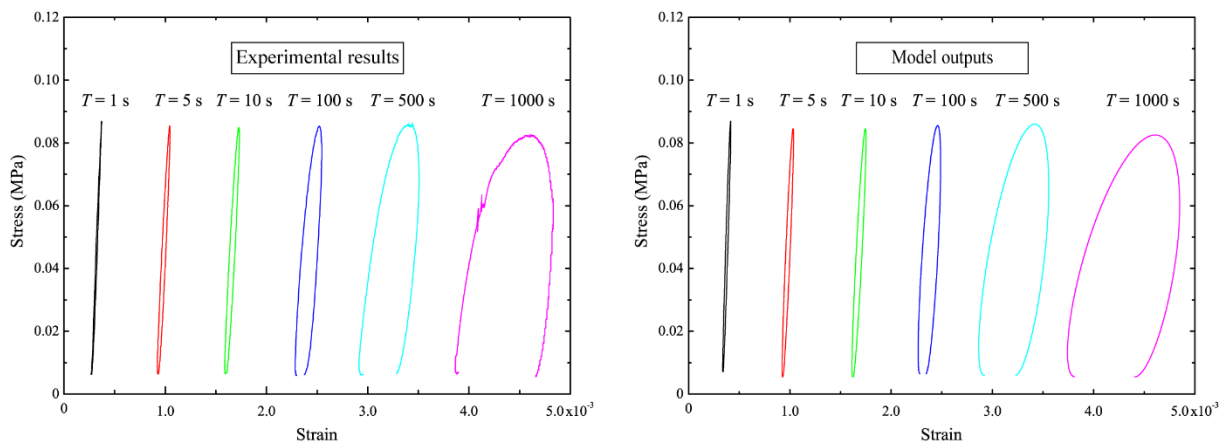

(b)

676

677

678

679

680

681

682

683

684

Figure 14. Comparison between the steady-state stress-strain hysteresis loops measured in the experiments and those predicted by the dislocation-based model for (a) specimen Dry-5ppt-1 tested with stresses varying from 0.1 to 0.3 MPa and with the temperature of -10°C and (b) specimen Floating-5ppt-1 tested with stresses varying from 0.005 to 0.085 MPa and with the average temperature of -2.5°C (note that, to compare the representative hysteresis loops in all the different-frequency experiments with those outputted by the model in a more concise and intuitive way, the pre-strains before the hysteresis loops drawn here are not equal to the experimental values).